



ETP-CLASSIC is available as standard for shafts 15-100 mm, also imperial and a short version, (type S). Also available in stainless steel (type R).
Runout: 0,03 – 0,06 mm. Number of mountings: 100 (type R: 50). The small number of clamping screws with low tightening torque, makes the mounting/dismantling procedure fast and easy.

Construction

ETP-CLASSIC is a hydraulic connection which consists of a double-walled hardened steel sleeve, filled with a specially developed pressure medium, sealing ring, piston, pressure flange and cap head clamping screws.

ETP-CLASSIC type R is made of stainless steel and has hex head stainless steel clamping screws. This in order to facilitate easy cleaning, essential within food processing.

Operation

When tightening the screws, the sleeve expands uniformly against hub and shaft and creates a rigid joint. When loosening the screws, the sleeve returns to its original measurements and can easily be dismantled.

ETP-CLASSIC type R has a few more clamping screws, as the tightening torque is lower for stainless steel screws.

BENEFITS & FEATURES

- Small built-in dimensions.
- Mounting and dismantling is fast.
- Fine adjustment of the hub can be made during mounting.
- Low tightening torque and a small number of screws makes the mounting easy.
- Good concentricity, also after several mountings.
- Hex head screws available as accessories.

When the screws have been tightened, ETP-CLASSIC creates an even surface pressure against the hub and shaft along virtually the entire length.

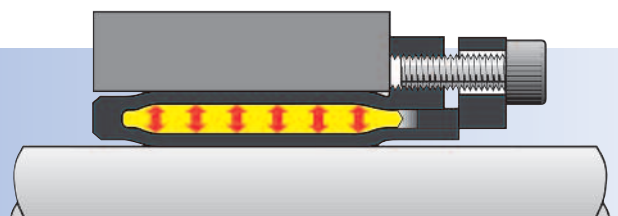



0,03 – 0,06



-30 – +85°



CAD

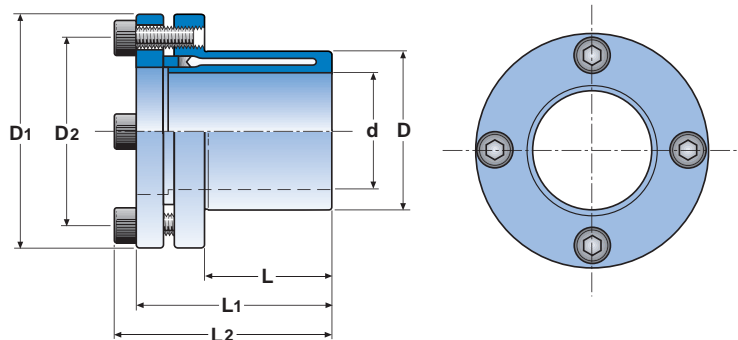

Notation: ETP-CLASSIC XXX

Technical Specification ETP-CLASSIC

ETP-CLASSIC	Dimensions							Transmittable torque axial force radial force			Screws DIN 912, 12.9			Polar moment of inertia J kgm ² · 10 ⁻³	Weight kg
	d mm	D mm	D ₁ mm	D ₂ mm	L mm	L ₁ * mm	L ₂ * mm	T Nm	F _A kN	F _R kN	No.	Dim.	T _t Nm		
15	15	23	38	28,5	17	30	35	55	7,3	2,5	3	M5	6	0,019	0,10
19	19	28	45	35	21	37	42	100	10,6	5,8	3	M5	8	0,045	0,17
20	20	28	45	35	22	37	42	125	12,5	6,6	3	M5	8	0,043	0,16
22	22	32	49	40	22	37	42	135	12,3	8,2	4	M5	8	0,063	0,20
24	24	34	49	40	25	40	45	200	16,7	9,8	4	M5	8	0,066	0,20
25	25	34	49	40	27	43	48	250	20,0	10,6	4	M5	8	0,067	0,20
28	28	39	55	46	29	45	50	300	21,4	13,1	4	M5	8	0,112	0,27
30	30	41	57	47,5	32	47	52	420	28,0	14,7	4	M5	8	0,133	0,30
32	32	43	60	50,5	34	52	57	420	26,3	16,3	4	M5	8	0,180	0,35
35	35	47	63	53,5	37	55	60	650	37,1	18,8	6	M5	8	0,230	0,41
38	38	50	65	56	41	59	64	750	39,5	21,2	6	M5	8	0,277	0,44
40	40	53	70	60,5	43	63	68	940	47,0	22,8	6	M5	8	0,408	0,57
42	42	55	70	60,5	45	65	70	940	44,8	24,4	6	M5	8	0,414	0,56
45	45	59	77	66,5	49	69	75	1290	57,3	26,9	6	M6	13	0,636	0,73
48	48	62	80	69,5	52	73	79	1570	65,4	29,3	6	M6	13	0,761	0,80
50	50	65	83	72,5	53	76	82	1900	76,0	30,9	6	M6	13	0,943	0,91
55	55	71	88	78	58	82	88	2500	90,9	35,0	8	M6	13	1,301	1,09
60	60	77	95	84,5	64	90	96	3400	113	39,1	8	M6	13	1,959	1,40
65	65	84	102	91	68	96	102	3500	108	43,1	8	M6	13	2,780	1,72
70	70	90	113	99	72	99	107	5200	149	47,2	6	M8	32	4,035	2,09
75	75	95	118	104	85	114	122	6300	168	51,3	6	M8	32	5,500	2,51
80	80	100	123	109	90	120	128	8800	220	55,0	6	M8	32	8,100	2,68
85	85	106	129	115	95	125	133	8800	207	58,0	6	M8	32	9,500	3,09
90	90	112	135	121	100	133	141	11000	244	60,0	8	M8	32	12,200	3,52
95	95	120	143	129	105	139	147	12800	269	61,5	8	M8	32	17,100	4,46
100	100	125	148	134	110	145	153	15500	310	62,0	8	M8	32	19,950	4,87

T= Transmittable torque when axial force is 0. } When the screw is tightened to T_t.
 F_A=Transmittable axial force when torque is 0. }
 F_R=Max transmittable radial force at continuous operation.
 Max allowed bending torque: 15% of transmittable torque T.

T_t= Recommended tightening torque for the screws.
 *) The dimensions are valid before mounting.

Dimensions subject to alterations without notice.

TOLERANCES

Shaft h8 – k6 (size 15 only h7)

When using k6 shaft – transmittable torque will increase by 20%.

Can also be used with h9 shaft – Transmittable torque will be reduced by 25%.

Hub H7.

Type of torque

Transmittable torque, T, is for static load.

If the load is alternating or pulsating torque, reduce the transmittable torque, T, with the following factors: (factor x T).

Alternating: 0,6 x T for sizes 15 – 30 mm.

0,5 x T for sizes 32 – 100 mm.

Pulsating: 0,7 x T for sizes 15 – 30 mm.

0,6 x T for sizes 32 – 100 mm.

Tightening torque

By increasing the tightening torque of the screw sizes according to the table, the transmittable torque can be increased by 25%.

Note: Only to be used when operating temperature ≤ mounting temperature.

Max. tightening torque (screw quality 12.9)

M5	M6	M8
10 Nm	17 Nm	40 Nm

Technical Specification ETP-CLASSIC in inch

ETP-CLASSIC®	Dimensions						Transmittable torque or axial force		Screws DIN 912, 12.9		
	d tum	D mm	D ₁ mm	L mm	L ₁ mm	L ₂ mm	T Nm	F _A kN	No.	Dim.	Tt Nm
3/4"	3/4"	28	45	21	35	40	88	9,3	3	M5	8
7/8"	7/8"	32	49	22	37	42	135	12,1	4	M5	8
15/16"	15/16"	34	49	25	39	44	175	14,7	4	M5	8
1"	1"	35	51	27	41	46	195	16,2	4	M5	8
1 1/8"	1 1/8"	39	55	29	43	48	280	19,5	4	M5	8
1 3/16"	1 3/16"	41	57	32	47	52	340	22,5	4	M5	8
1 1/4"	1 1/4"	43	60	34	50	55	410	26,1	4	M6	13
1 3/8"	1 3/8"	47	63	37	53	58	540	31,1	6	M5	8
1 7/16"	1 7/16"	50	65	37	54	59	580	31,8	6	M5	8
1 1/2"	1 1/2"	52	68	41	57	62	700	36,7	6	M5	8
1 5/8"	1 5/8"	55	70	44	63	68	850	41,2	6	M5	8
1 3/4"	1 3/4"	59	77	49	67	73	1180	53,0	6	M6	13
1 15/16"	1 15/16"	65	83	52	74	80	1450	58,9	6	M6	13
2"	2"	68	88	53	74	80	1620	64,3	6	M6	13
2 7/16"	2 7/16"	81	99	60	85	91	2800	90,5	8	M6	13
2 1/2"	2 1/2"	84	107	62	86	94	3100	97,6	6	M8	32
2 15/16"	2 15/16"	95	118	85	108	116	5300	153,0	6	M8	32
3"	3"	98	121	74	101	109	5300	139,1	6	M8	32
4"	4"	130	155	97	128	136	12500	264,0	8	M8	32

ETP-CLASSIC is also available in a large assortment of inch sizes. The main dimensions are given in the table, for more information please refer to technical data for ETP-CLASSIC.

TOLERANCES

ETP-CLASSIC	Shaft tolerance
3/4"	0 to -0,0015"
7/8" – 1 1/2"	0 to -0,0020"
1 5/8" – 2 15/16"	0 to -0,0030"
3"	0 to -0,0040"
4"	0 to -0,0030"

ETP-CLASSIC	Hub tolerance
3/4" - 1 15/16"	0 to +0,0010"
2" – 2 7/16"	0 to +0,0012"
2 1/2" – 4"	0 to +0,0014"

Notation ETP-CLASSIC S-XX

Technical Specification ETP-CLASSIC type S

ETP-CLASSIC®	Dimensions						Transmittable torque or axial force		Screws DIN 912, 12.9			Weight kg
	d mm	D mm	D ₁ mm	L mm	L ₁ mm	L ₂ mm	T Nm	F _A kN	No.	Dim.	Tt Nm	
S-19	19	28	45	13	26	31	53	5	3	M5	8	0,15
S-20	20	28	45	15	28	33	75	6	3	M5	8	0,14
S-25	25	34	49	15	29	34	120	10	4	M5	8	0,17
S-30	30	41	57	20	34	39	210	14	4	M5	8	0,24
S-35	35	47	63	22	38	43	330	19	6	M5	8	0,32
S-40	40	53	70	25	42	47	500	26	6	M5	8	0,46
S-45	45	59	77	28	45	51	700	31	6	M6	13	0,57
S-50	50	65	83	26	45	51	1000	40	6	M6	13	0,72

ETP-CLASSIC is also available in a shorter version, type S, which is especially suitable for small hubs. The main dimensions are given in the table, for more information please refer to technical data for ETP-CLASSIC.

TOLERANCES

Shaft: h9 (for size 19: k6-h8).

Hub: H7.



Notation: ETP-CLASSIC R-XX

Technical Specification ETP-CLASSIC R

ETP-CLASSIC®	Dimensions							Transmittable torque axial force radial force			Screws**) DIN 933, A4			Polar moment of inertia J kgm ² · 10 ⁻³	Weight kg
	d mm	D mm	D ₁ mm	D ₂ mm	L mm	L ₁ * mm	L ₂ * mm	T Nm	F _A kN	F _R kN	Ant.	Dim.	Tt Nm		
R-15	15	23	38	28,5	17	30	34	45	6,0	2,5	4	M5	4,5	0,019	0,10
R-20	20	28	45	35	22	37	41	100	10,0	6,6	5	M5	4,5	0,044	0,16
R-25	25	34	49	40	27	43	47	210	16,8	10,6	7	M5	4,5	0,070	0,21
R-30	30	41	57	47,5	32	47	51	350	23,3	14,7	7	M5	4,5	0,137	0,30
R-35	35	47	63	53,5	37	55	59	500	28,5	18,8	9	M5	4,5	0,234	0,41
R-40	40	53	70	60,5	43	63	67	750	37,5	22,8	9	M5	4,5	0,414	0,58
R-45	45	59	77	66,5	49	69	73	1100	48,8	26,9	9	M6	7,8	0,647	0,74
R-50	50	65	83	72,5	53	76	80	1550	62,0	30,9	9	M6	7,8	0,957	0,92

T= Transmittable torque when axial force is 0. } When the screw is tightened to Tt.
 F_A=Transmittable axial force when torque is 0. }
 F_R=Max transmittable radial force at continuous operation.
 Max allowed bending torque: 15% of transmittable torque T.

Tt= Recommended tightening torque for the screws.
 *) The dimensions are valid before mounting.

Dimensions subject to alterations without notice.

TOLERANCES

Shaft h8 (size R-15 only h7)

Hub H7.

Material

Euronorm 1.4542, stainless steel, X5CrNiCuNb16-4.

**)Screws: coated for a low and even friction in the threads.

Mounting advice

Make sure the screw thread is well lubricated before each mounting.

We recommend the use of Molykote P-1900.