

BS Compact Ball Screw

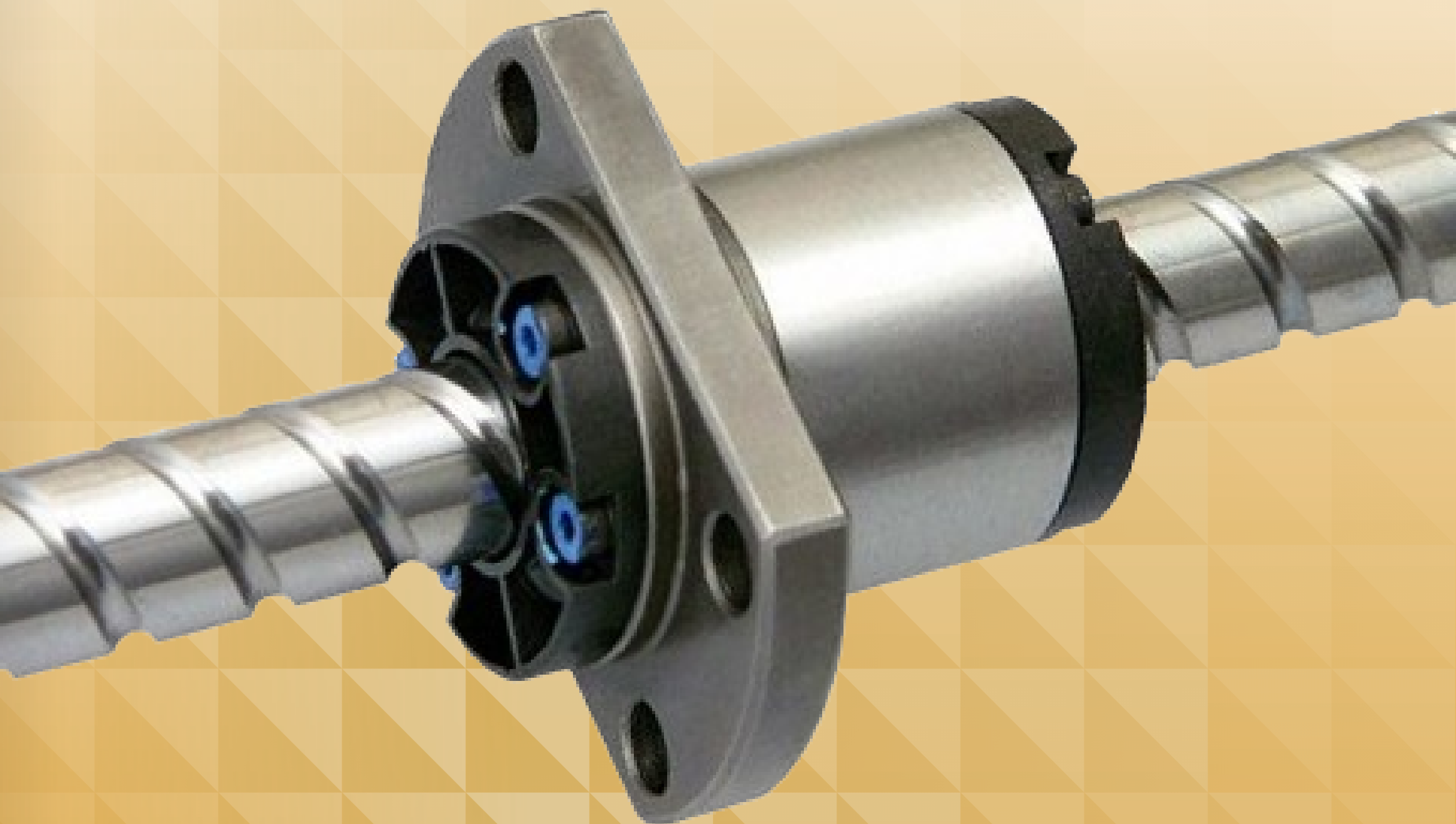

→ BS Compact Ball Screw

Call: 01386 421 005

Email: sales@abssac.co.uk

Web: www.abssac.co.uk

ABSSAC
PRECISION MOTION SINCE 1982

Precision Ball Screws

Sleeve type Single Nut

Backlash type/Preload type

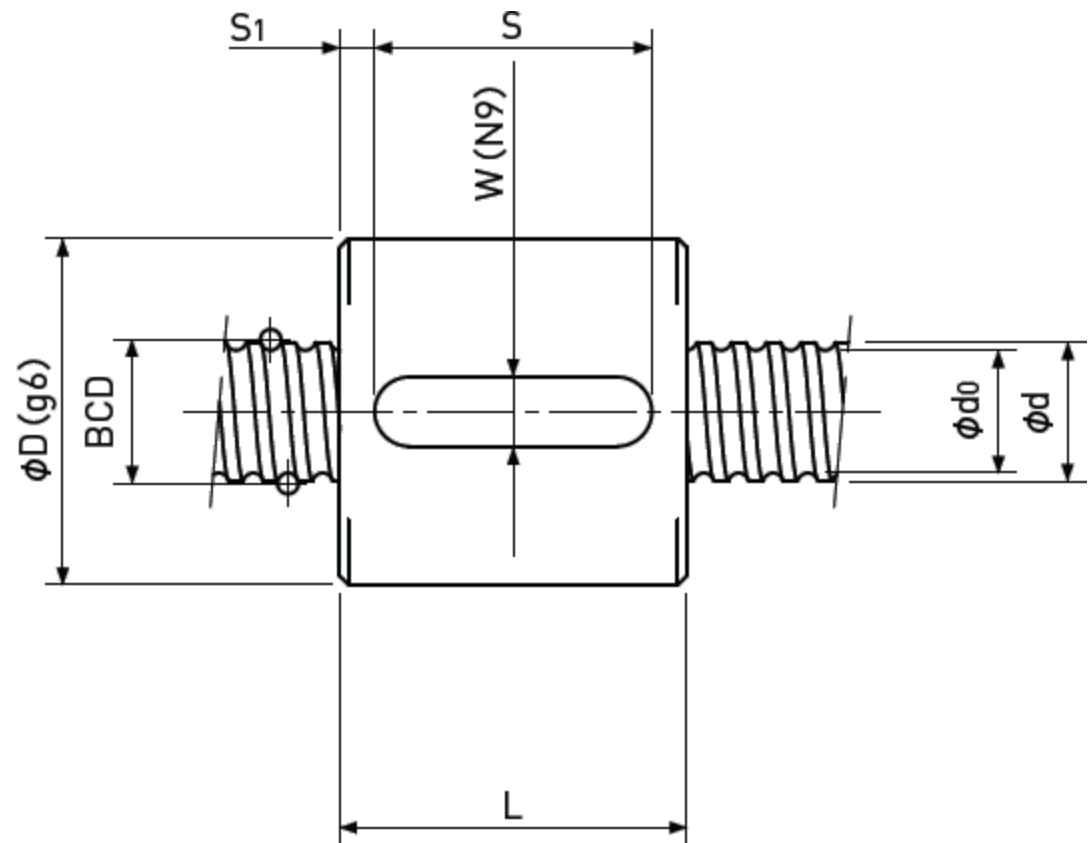
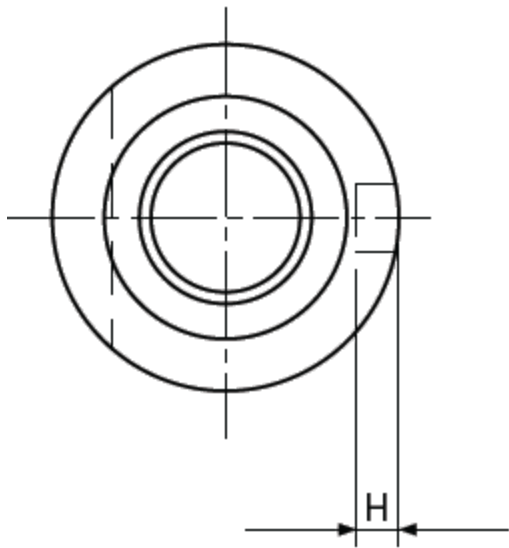

Unit : mm

Ball Nut Model number	Shaft nominal dia. d	Lead	Ball size	BCD	Lead angle	Root dia. d ₀	Number of Circuit	Basic Load Rating N		Nut Rigidity N/μm
								Dynamic Ca	Static Coa	
BS 0301 B	3	1	0.6	3.18	5°43'	2.4	3.7×1	330 / -	440 / -	42 / -
BS 0401 A	4	1	0.8	4.15	4°23'	3.3	2.7×1	420 / 270	570 / 290	40 / 34
BS 0401 B	4	1	0.8	4.15	4°23'	3.3	3.7×1	560 / 350	790 / 400	54 / 45
BS 0402 A	4	2	0.8	4.15	8°43'	3.3	2.7×1	420 / 260	570 / 290	39 / 33
BS 0403 A	4	3	0.8	4.15	12°57'	3.3	2.7×1	420 / -	570 / -	39 / -
BS 0501 B	5	1	0.8	5.15	3°32'	4.3	3.7×1	630 / 400	1000 / 500	65 / 55
BS 0504 A	5	4	0.8	5.15	13°53'	4.3	2.7×1	470 / 300	720 / 360	47 / 39
BS 0601 B	6	1	0.8	6.15	2°58'	5.3	3.7×1	680 / 430	1200 / 610	75 / 63
BS 0601.5 B	6	1.5	1	6.2	4°24'	5.1	3.7×1	980 / 620	1600 / 800	79 / 67
BS 0602 A	6	2	1	6.2	5°52'	5.1	2.7×1	750 / 470	1200 / 590	58 / 49
BS 0602 B	6	2	1	6.2	5°52'	5.1	3.7×1	980 / 620	1600 / 800	79 / 67
BS 0602.5 A	6	2.5	1	6.2	7°19'	5.1	2.7×1	750 / 470	1200 / 590	59 / 49

Ball Nut Model number	Nut dimension					
	D	L	W	H	S	S ₁
BS 0301 B	9	12	2	1.2	8	2
BS 0401 A	10	12	2	1.2	8	2
BS 0401 B	11	14	3	1.8	8	3
BS 0402 A	11	16	3	1.8	8	4
BS 0403 A	11	20	3	1.8	8	6
BS 0501 B	12	14	3	1.8	8	3
BS 0504 A	12	22	3	1.8	12	5
BS 0601 B	13	14	3	1.8	10	2
BS 0601.5 B	14	16	3	1.8	10	3
BS 0602 A	15	15	3	1.8	10	2.5
BS 0602 B	15	18	3	1.8	12	3
BS 0602.5 A	15	16	3	1.8	10	3

Basic Load Rating N		Nut Rigidity N/μm
Dynamic Ca	Static Coa	
1000 / 640	3300 / 1650	164 / 138

- Note 1) The diameter of one of the Screw Shaft ends must be less than the Screw Shaft Root diameter, otherwise Ball Nut cannot be installed.
- Note 2) Ball Nut dimension is without seal at both ends. If the seals are required, Ball Nut dimension should be changed, in that case, please ask ABSSAC. Some type of Ball Nuts cannot equip with seals, please ask ABSSAC representative.
- Note 3) The Rigidity values shown in the table are theoretical values of Ball Nut Rigidity calculated from the amount of Elastic Displacement under the following conditions. Backlash type; Apply the Axial load equivalent to 30% of the Basic Dynamic Load Rating Ca. Preload type; Apply the Preload equivalent to 5% of the Basic Dynamic Load Rating Ca. For Axial load or Preload condition other than the above, see the formula in p-A823, you can calculate Rigidity using this formula.
- Note 4) All models are Right-hand screw. If Left-hand screw is required, please ask ABSSAC representative.
- Note 5) Basic Load Rating and Rigidity for Backlash type and Preload type are described in the same cell.

Precision Ball Screws

Sleeve type Single Nut

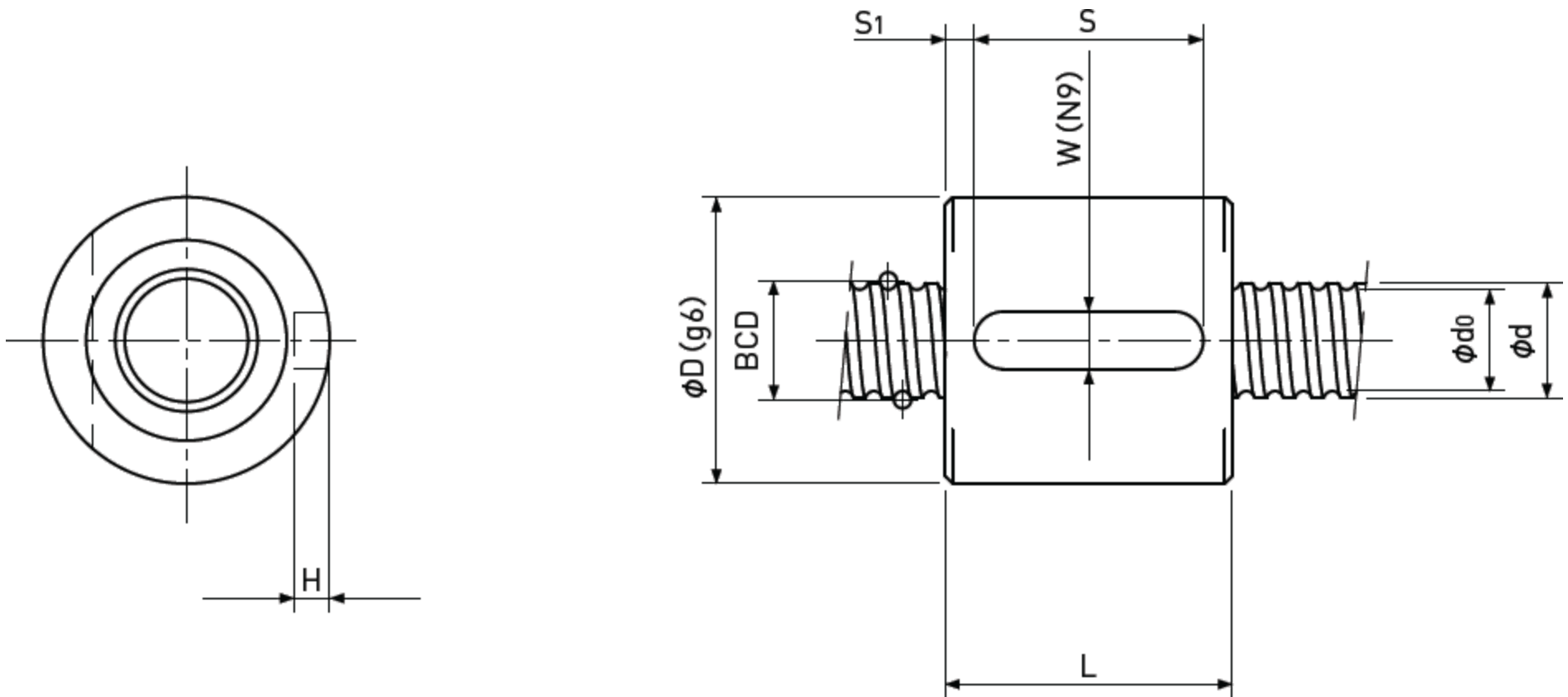

Backlash type/Preload type



Unit : mm

Ball Nut Model number	Shaft nominal dia. d	Lead	Ball size	BCD	Lead angle	Root dia. d ₀	Number of Circuit	Basic Load Rating N		Nut Rigidity N/μm
								Dynamic Ca	Static Coa	
BS 0801 B	8	1	0.8	8.15	2°15'	7.3	3.7×1	780 / 490	1650 / 820	95 / 80
BS 0801.5 B	8	1.5	1	8.2	3°20'	7.1	3.7×1	1100 / 700	2200 / 1100	99 / 83
BS 0802 A□(1)	8	2	1	8.2	4°26'	7.1	2.7×1	850 / 540	1600 / 800	74 / 61
BS 0802 B□(1)	8	2	1	8.2	4°26'	7.1	3.7×1	1100 / 700	2200 / 1100	99 / 83
BS 0802 A□(2)	8	2	1.5875	8.3	4°23'	6.6	2.7×1	1850 / 1150	3000 / 1500	82 / 69
BS 0802 B□(2)	8	2	1.5875	8.3	4°23'	6.6	3.7×1	2400 / 1550	4100 / 2100	111 / 94
BS 0802.5 A□(1)	8	2.5	1.5875	8	5°41'	6.3	2.7×1	1850 / -	3000 / -	80 / -
BS 0802.5 A□(2)	8	2.5	1.5875	8.3	5°29'	6.6	2.7×1	1850 / 1150	3000 / 1500	82 / 69
BS 0802.5 B	8	2.5	1.5875	8.3	5°29'	6.6	3.7×1	2400 / 1550	4100 / 2100	111 / 93
BS 0803 A	8	3	2	8.3	6°34'	6.2	2.7×1	2600 / 1650	4200 / 2100	85 / 70
BS 0803 B	8	3	2	8.3	6°34'	6.2	3.7×1	3500 / 2200	5700 / 2800	116 / 97
BS 0804 A	8	4	2	8.3	8°43'	6.2	2.7×1	2600 / 1650	4200 / 2100	84 / 70
BS 0805 A	8	5	1.5875	8.3	10°51'	6.6	2.7×1	1850 / 1150	3000 / 1500	82 / 67

Ball Nut Model number	Nut dimension					
	D	L	W	H	S	S ₁
BS 0801 B	16	14	3	1.8	10	2
BS 0801.5 B	16	16	3	1.8	10	3
BS 0802 A□(1)	16	15	3	1.8	10	2.5
BS 0802 B□(1)	16	18	3	1.8	12	3
BS 0802 A□(2)	20	17	4	2.5	12	2.5
BS 0802 B□(2)	20	20	4	2.5	16	2
BS 0802.5 A□(1)	16	16	3	1.8	8	4
BS 0802.5 A□(2)	20	19	4	2.5	12	3.5
BS 0802.5 B	20	22	4	2.5	16	3
BS 0803 A	20	22	4	2.5	16	3
BS 0803 B	20	26	4	2.5	20	3
BS 0804 A	21	26	4	2.5	20	3
BS 0805 A	18	28	4	2.5	20	4

Basic Load Rating N		Nut Rigidity N/μm
Dynamic Ca	Static Coa	
1000 / 640	3300 / 1650	164 / 138
 Preload type  Backlash type		

- Note 1)
- Note 2)
- Note 3)
- Note 4)
- Note 5)

The diameter of one of the Screw Shaft ends must be less than the Screw Shaft Root diameter, otherwise Ball Nut cannot be installed.

Ball Nut dimension is without seal at both ends. If the seals are required, Ball Nut dimension should be changed, in that case, please ask ABSSAC. Some type of Ball Nuts cannot equip with seals, please ask ABSSAC representative.

The Rigidity values shown in the table are theoretical values of Ball Nut Rigidity calculated from the amount of Elastic Displacement under the following conditions. Backlash type; Apply the Axial load equivalent to 30% of the Basic Dynamic Load Rating Ca. Preload type; Apply the Preload equivalent to 5% of the Basic Dynamic Load Rating Ca. For Axial load or Preload condition other than the above, see the formula in p-A823, you can calculate Rigidity using this formula.

All models are Right-hand screw. If Left-hand screw is required, please ask ABSSAC representative.

Basic Load Rating and Rigidity for Backlash type and Preload type are described in the same cell.

Precision Ball Screws

Sleeve type Single Nut

Backlash type/Preload type

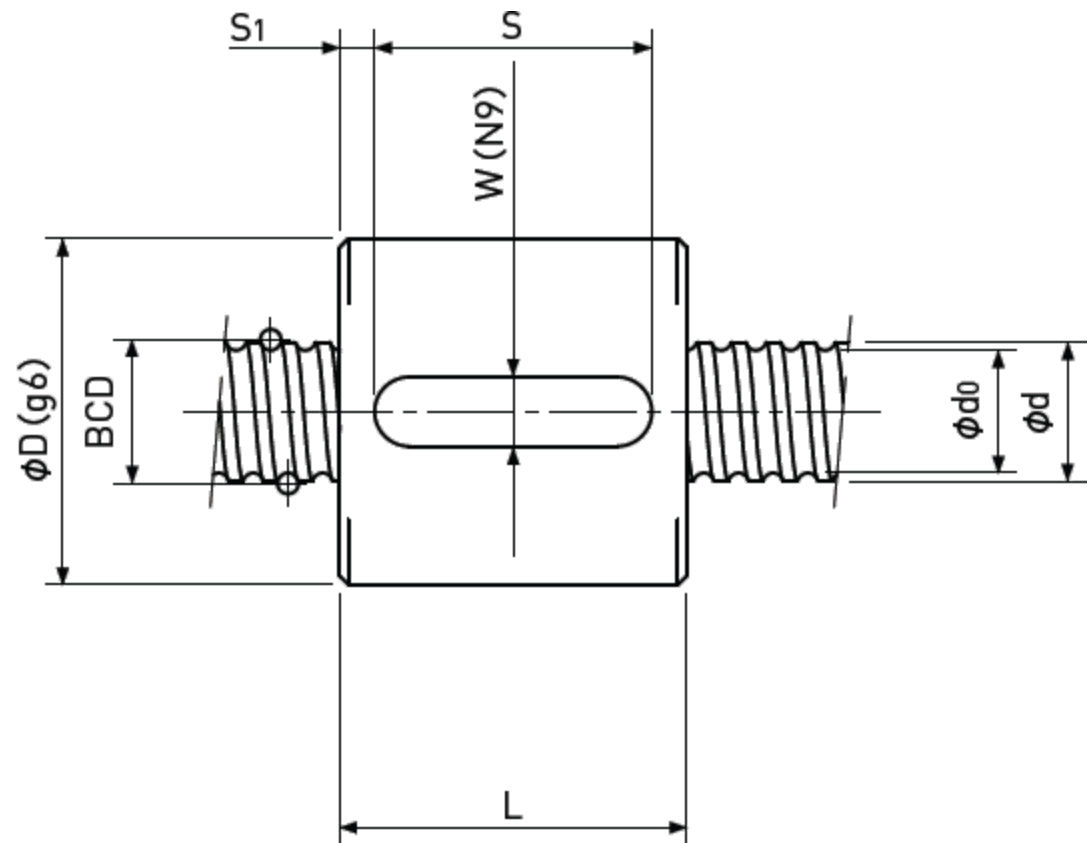
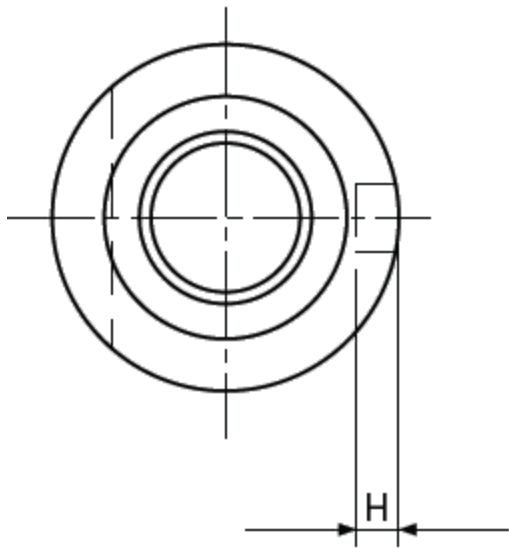

Unit : mm

Ball Nut Model number	Shaft nominal dia. d	Lead	Ball size	BCD	Lead angle	Root dia. d ₀	Number of Circuit	Basic Load Rating N		Nut Rigidity N/μm
								Dynamic Ca	Static Coa	
BS 1001 B	10	1	0.8	10.15	1°48'	9.3	3.7×1	840 / 530	2000 / 1000	113 / 95
BS 1001.5 B	10	1.5	1	10.2	2°41'	9.1	3.7×1	1250 / 790	2800 / 1400	120 / 101
BS 1002 A	10	2	1.5875	10.3	3°32'	8.6	2.7×1	2100 / 1300	3800 / 1900	100 / 82
BS1002 B	10	2	1.5875	10.3	3°32'	8.6	3.7×1	2700 / 1750	5300 / 2700	134 / 112
BS 1002.5 A	10	2.5	1.5875	10.3	4°25'	8.6	2.7×1	2100 / 1300	3800 / 1900	100 / 82
BS 1002.5 B	10	2.5	1.5875	10.3	4°25'	8.6	3.7×1	2700 / 1750	5300 / 2700	133 / 112
BS 1003 A	10	3	2	10.3	5°18'	8.2	2.7×1	3000 / 1800	5200 / 2600	103 / 84
BS 1003 B	10	3	2	10.3	5°18'	8.2	3.7×1	3900 / 2500	7200 / 3600	140 / 118
BS 1004 A	10	4	2	10.3	7°03'	8.2	2.7×1	3000 / 1800	5200 / 2600	104 / 86
BS 1004 B	10	4	2	10.3	7°03'	8.2	3.7×1	3900 / 2500	7200 / 3600	139 / 118
BS 1005 A□(1)	10	5	2	10.3	8°47'	8.2	2.7×1	3000 / -	5200 / -	103 / -
BS 1005 A□(2)	10	5	2	10.3	8°47'	8.2	2.70×1	3000 / 1800	5200 / 2600	103 / 85

Ball Nut Model number	Nut dimension					
	D	L	W	H	S	S ₁
BS 1001 B	19	14	3	1.8	10	2
BS 1001.5 B	19	16	3	1.8	10	3
BS 1002 A	23	17	5	3	12	2.5
BS1002 B	23	20	5	3	16	2
BS 1002.5 A	24	19	5	3	12	3.5
BS 1002.5 B	24	22	5	3	16	3
BS 1003 A	24	22	5	3	16	3
BS 1003 B	24	26	5	3	20	3
BS 1004 A	24	26	5	3	20	3
BS 1004 B	24	30	5	3	20	5
BS 1005 A□(1)	23	26	5	3	16	5
BS 1005 A□(2)	24	34	5	3	28	3

Basic Load Rating N		Nut Rigidity N/μm
Dynamic Ca	Static Coa	
1000 / 640	3300 / 1650	164 / 138
<div style="display: flex; align-items: center;"> <div style="border: 1px solid black; width: 10px; height: 10px; margin-right: 5px;"></div> <div style="border: 1px solid black; width: 10px; height: 10px; margin-right: 5px; margin-left: 5px;"></div> <div style="margin-left: 5px;">Preload type</div> </div> <div style="display: flex; align-items: center; margin-top: 5px;"> <div style="border: 1px solid black; width: 10px; height: 10px; margin-right: 5px;"></div> <div style="margin-left: 5px;">Backlash type</div> </div>		

- Note 1) The diameter of one of the Screw Shaft ends must be less than the Screw Shaft Root diameter, otherwise Ball Nut cannot be installed.
- Note 2) Ball Nut dimension is without seal at both ends. If the seals are required, Ball Nut dimension should be changed, in that case, please ask ABSSAC. Some type of Ball Nuts cannot equip with seals, please ask ABSSAC representative.
- Note 3) The Rigidity values shown in the table are theoretical values of Ball Nut Rigidity calculated from the amount of Elastic Displacement under the following conditions. Backlash type; Apply the Axial load equivalent to 30% of the Basic Dynamic Load Rating Ca. Preload type; Apply the Preload equivalent to 5% of the Basic Dynamic Load Rating Ca. For Axial load or Preload condition other than the above, see the formula in p-A823, you can calculate Rigidity using this formula.
- Note 4) All models are Right-hand screw. If Left-hand screw is required, please ask ABSSAC representative.
- Note 5) Basic Load Rating and Rigidity for Backlash type and Preload type are described in the same cell.

Precision Ball Screws

Sleeve type Single Nut

Backlash type/Preload type

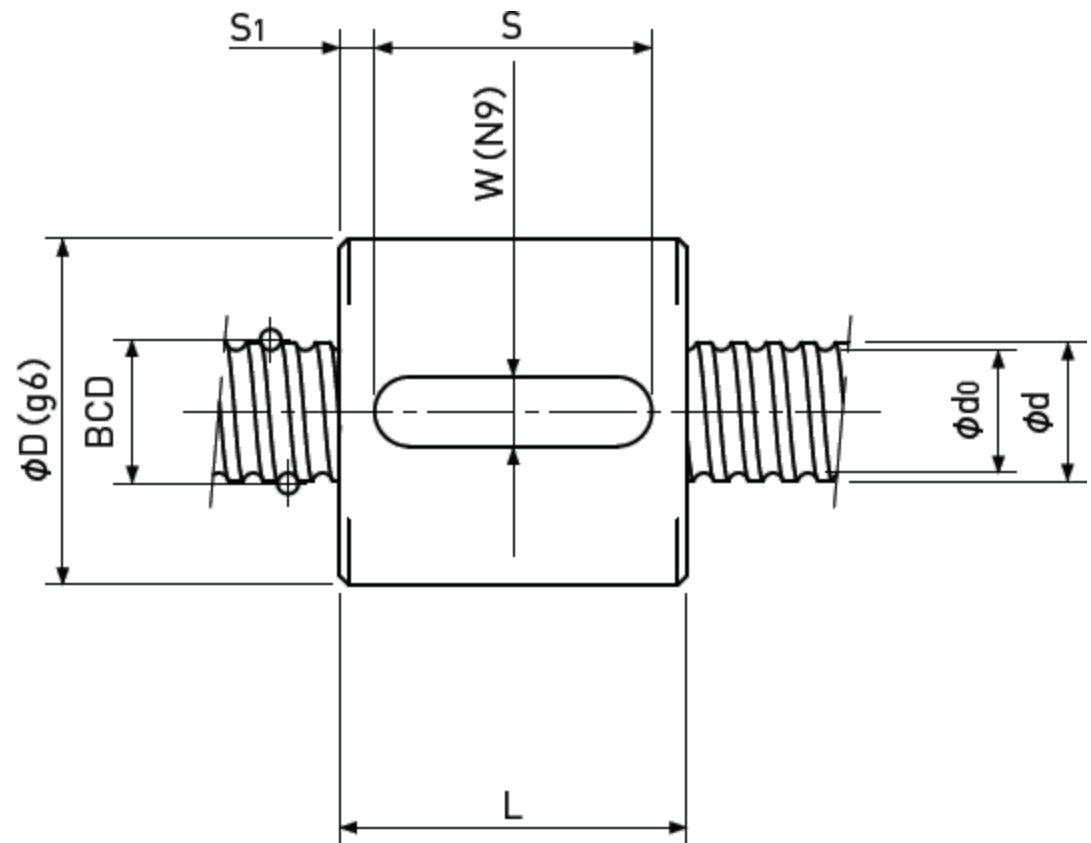
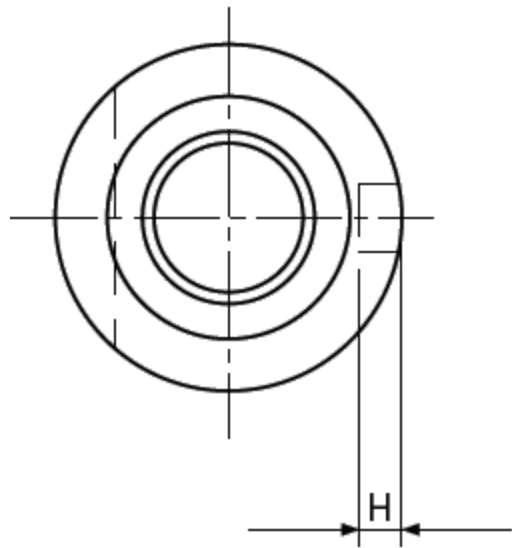

Unit : mm

Ball Nut Model number	Shaft nominal dia. d	Lead	Ball size	BCD	Lead angle	Root dia. d ₀	Number of Circuit	Basic Load Rating N		Nut Rigidity N/μm
								Dynamic Ca	Static Coa	
BS 1201 B	12	1	0.8	12.15	1°30'	11.3	3.7×1	910 / 570	2400 / 1200	131 / 110
BS 1202 B	12	2	1.5875	12.3	2°58'	10.6	3.7×1	3000 / 1900	6400 / 3200	156 / 132
BS 1202.5 B	12	2.5	1.5875	12.3	3°42'	10.6	3.7×1	3000 / 1850	6400 / 3200	156 / 130
BS 1203 B	12	3	2	12.3	4°26'	10.2	3.7×1	4300 / 2800	8700 / 4300	162 / 137
BS 1204 B	12	4	2.381	12.3	5°55'	9.8	3.7×1	5400 / 3400	10200 / 5100	165 / 139
BS 1205 A	12	5	2.381	12.3	7°22'	9.8	2.7×1	4100 / 2500	7400 / 3700	122 / 101
BS 1401 B	14	1	0.8	14.15	1°17'	13.3	3.7×1	960 / 610	2900 / 1450	148 / 124
BS 1402 B	14	2	1.5875	14.3	2°33'	12.6	3.7×1	3200 / 2000	7500 / 3800	176 / 148
BS 1402.5 B	14	2.5	1.5875	14.3	3°11'	12.6	3.7×1	3200 / 2000	7500 / 3700	176 / 148
BS 1403 B	14	3	2	14.3	3°49'	12.2	3.7×1	4600 / 2900	10100 / 5000	184 / 154
BS 1404 B	14	4	2.381	14.3	5°05'	11.8	3.7×1	5700 / 3600	11600 / 5800	187 / 157
BS 1405 B	14	5	2.381	14.3	6°21'	11.8	3.7×1	5700 / 3600	11600 / 5800	186 / 157

Ball Nut Model number	Nut dimension					
	D	L	W	H	S	S ₁
BS 1201 B	22	14	4	2.5	10	2
BS 1202 B	25	20	5	3	16	2
BS 1202.5 B	26	22	5	3	16	3
BS 1203 B	28	26	5	3	20	3
BS 1204 B	28	31	5	3	25	3
BS 1205 A	28	31	5	3	25	3
BS 1401 B	26	16	5	3	10	3
BS 1402 B	26	20	5	3	16	2
BS 1402.5 B	28	22	5	3	16	3
BS 1403 B	30	26	5	3	20	3
BS 1404 B	30	31	5	3	25	3
BS 1405 B	30	38	5	3	28	5

Basic Load Rating N		Nut Rigidity N/μm
Dynamic Ca	Static Coa	
1000 / 640	3300 / 1650	164 / 138

- Note 1) The diameter of one of the Screw Shaft ends must be less than the Screw Shaft Root diameter, otherwise Ball Nut cannot be installed.
- Note 2) Ball Nut dimension is without seal at both ends. If the seals are required, Ball Nut dimension should be changed, in that case, please ask ABSSAC. Some type of Ball Nuts cannot equip with seals, please ask ABSSAC representative.
- Note 3) The Rigidity values shown in the table are theoretical values of Ball Nut Rigidity calculated from the amount of Elastic Displacement under the following conditions. Backlash type; Apply the Axial load equivalent to 30% of the Basic Dynamic Load Rating Ca. Preload type; Apply the Preload equivalent to 5% of the Basic Dynamic Load Rating Ca. For Axial load or Preload condition other than the above, see the formula in p-A823, you can calculate Rigidity using this formula.
- Note 4) All models are Right-hand screw. If Left-hand screw is required, please ask ABSSAC representative.
- Note 5) Basic Load Rating and Rigidity for Backlash type and Preload type are described in the same cell.

Precision Ball Screws

Sleeve type Single Nut

Backlash type/Preload type

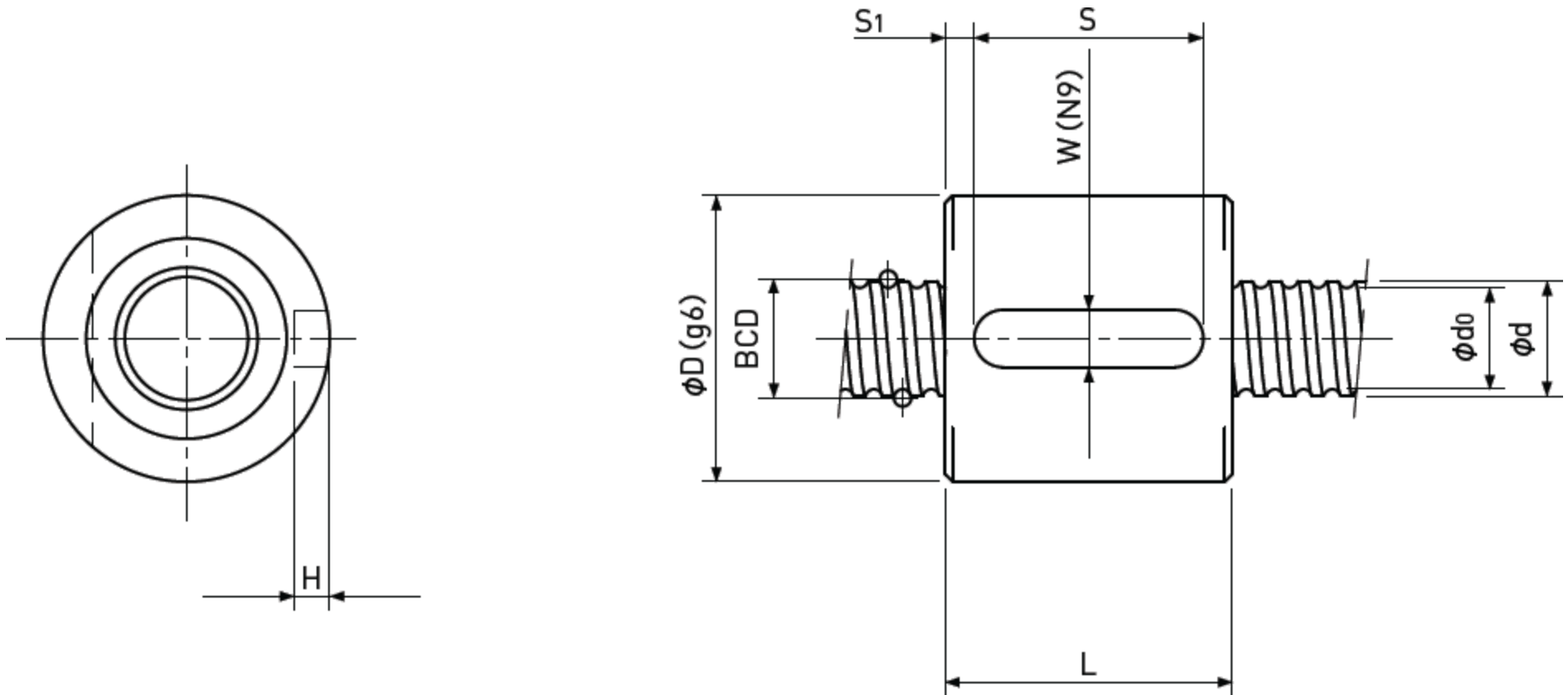

Unit : mm

Ball Nut Model number	Shaft nominal dia. d	Lead	Ball size	BCD	Lead angle	Root dia. d ₀	Number of Circuit	Basic Load Rating N		Nut Rigidity N/μm
								Dynamic Ca	Static Coa	
BS 1601 B	16	1	0.8	16.15	1°08'	15.3	3.7×1	1000 / 640	3300 / 1650	164 / 138
BS 1602 B	16	2	1.5875	16.3	2°14'	14.6	3.7×1	3400 / 2100	8600 / 4300	197 / 163
BS 1602.5 B	16	2.5	1.5875	16.3	2°48'	14.6	3.7×1	3400 / 2100	8600 / 4300	197 / 163
BS 1603 B	16	3	2	16.3	3°21'	14.2	3.7×1	4900 / 3100	11600 / 5800	205 / 172
BS 1604 B	16	4	2.381	16.3	4°28'	13.8	3.7×1	6200 / 3900	13600 / 6800	209 / 174
BS 1605 B	16	5	3.175	16.5	5°31'	13.2	3.7×1	9100 / 5700	18200 / 9100	217 / 182

Ball Nut Model number	Nut dimension					
	D	L	W	H	S	S ₁
BS 1601 B	28	16	5	3	10	3
BS 1602 B	28	20	5	3	16	2
BS 1602.5 B	28	22	5	3	16	3
BS 1603 B	32	26	5	3	20	3
BS 1604 B	34	32	5	3	25	3.5
BS 1605 B	38	38	5	3	28	5

Basic Load Rating N		Nut Rigidity N/μm
Dynamic Ca	Static Coa	
1000 / 640	3300 / 1650	164 / 138
		Preload type
		Backlash type

- Note 1) The diameter of one of the Screw Shaft ends must be less than the Screw Shaft Root diameter, otherwise Ball Nut cannot be installed.
- Note 2) Ball Nut dimension is without seal at both ends. If the seals are required, Ball Nut dimension should be changed, in that case, please ask ABSSAC. Some type of Ball Nuts cannot equip with seals, please ask ABSSAC representative.
- Note 3) The Rigidity values shown in the table are theoretical values of Ball Nut Rigidity calculated from the amount of Elastic Displacement under the following conditions. Backlash type; Apply the Axial load equivalent to 30% of the Basic Dynamic Load Rating Ca. Preload type; Apply the Preload equivalent to 5% of the Basic Dynamic Load Rating Ca. For Axial load or Preload condition other than the above, see the formula in p-A823, you can calculate Rigidity using this formula.
- Note 4) All models are Right-hand screw. If Left-hand screw is required, please ask ABSSAC representative.
- Note 5) Basic Load Rating and Rigidity for Backlash type and Preload type are described in the same cell.