

Linear Guides and Rails

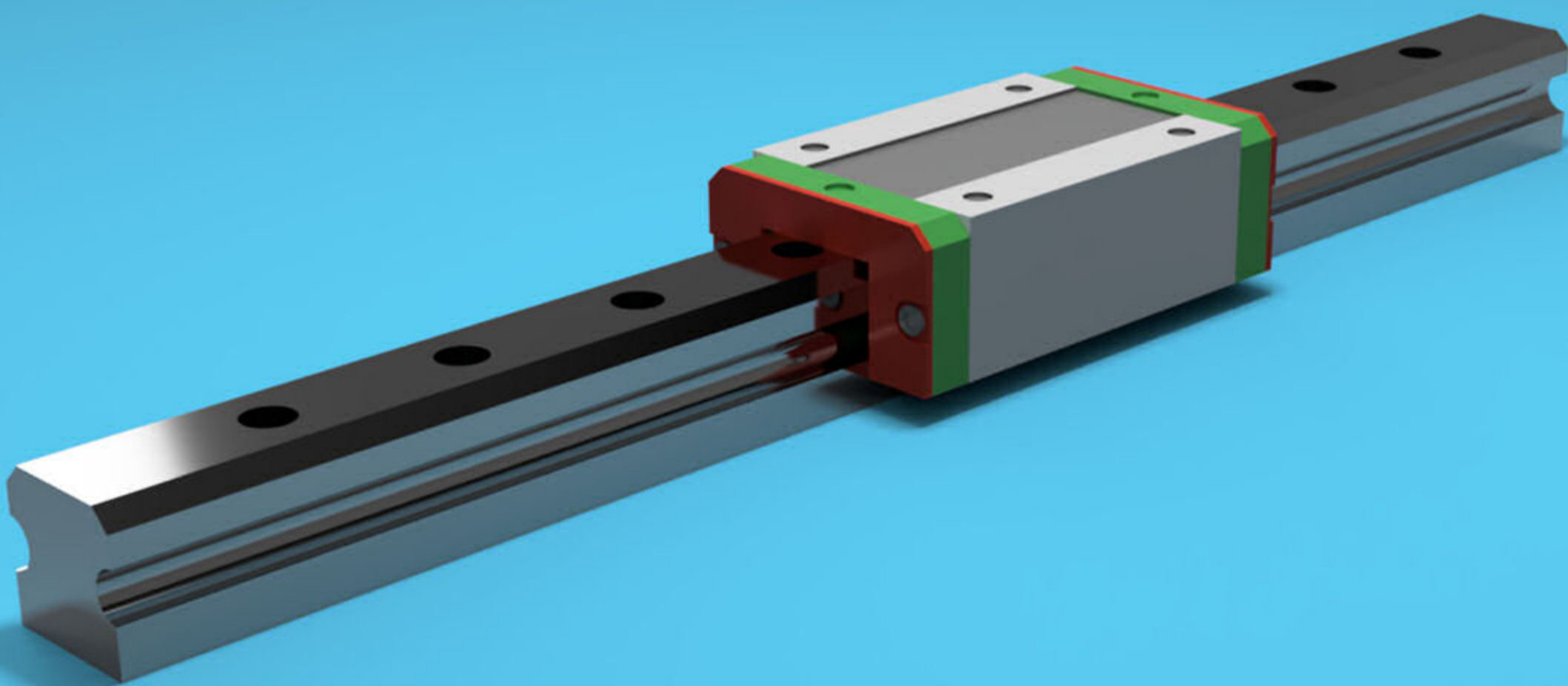

ABSSAC

PRECISION MOTION SINCE 1982



LINEAR GUIDES AND RAILS

At Absac, we concentrate on the flanged mount and square mount versions of linear guides. These items are in stock and have proven to be the best linear guide solution when teamed up with any of our ball and lead screw products. Dimensional data for these models can be accessed by the buttons above but we do encourage you to contact our knowledgeable sales team who can help you with the right selection..

By primarily using a four ball path design, within the slide, allows the guides to accept up to 30% more load and up to 30% stiffer than similar products in the market. An added bonus is that the ball bearings are retained within the housing so that should the guides come off the end of the rail, you will not be faced with all the ball bearings falling out. From experience, we know that this advantage can also significantly aid in the final assembly.

Typical Guide applications include:

- Grinders
- NC Lathes
- Machining centres
- Precision milling
- Automation technology
- Transportation technology
- Measuring applications
- Machines that require a high level of positional accuracy
- Ideal for use with our Transport ball screw ranges

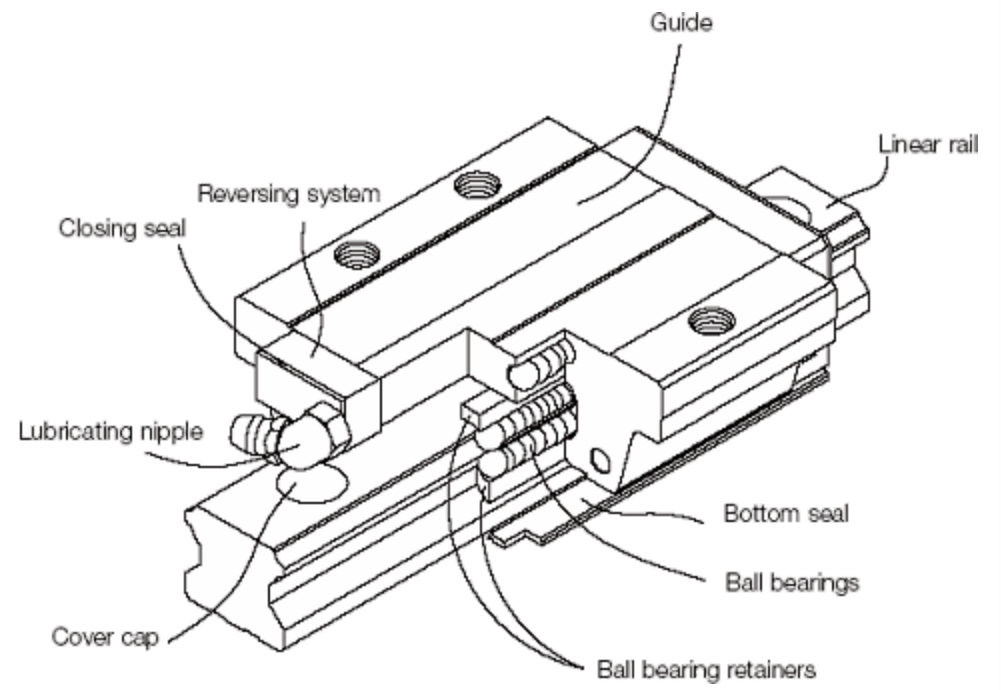

We also offer the advantage of supplying lightly pre-loaded heavy duty or extra heavy duty guide models to suit individual applications. When compared to other slide mechanisms such as dovetail slides, efficiency is far greater. The linear guides can carry loads in both horizontal and vertical directions. Please also note that the rails are pre drilled for ease of fitting and can be delivered cut to your desired length at no extra cost. Please note that all guides come with dust proofing seals at each end.

Available rail widths from 15mm to 65mm cater from the lightest to the heaviest load. If your application requires an accurate support and guide, our ex-stock range of linear rails may be the answer to your design challenges. Rails can be supplied from 100mm to 4000mm in length and in some cases can be attached to the application from beneath.

Typical Performance Data

HG Series 25, 30, 35	Normal	High	Precision	Super Precision	Ultra Precision
Accuracy Class	+/- 0.1mm	+/- 0.04mm	+/- 0	+/- 0	+/- 0
Height Tolerance H1	+/- 0.1mm	+/- 0.04mm	+ 0 / - 0.04mm	+ 0 / 0.02mm	+ 0 / 0.01mm
Width Tolerance N1	+/- 0.1mm	+/- 0.04mm	+ 0 / - 0.04mm	+ 0 / 0.02mm	+ 0 / 0.01mm

LINEAR GUIDES AND RAILS - DIMENSIONS

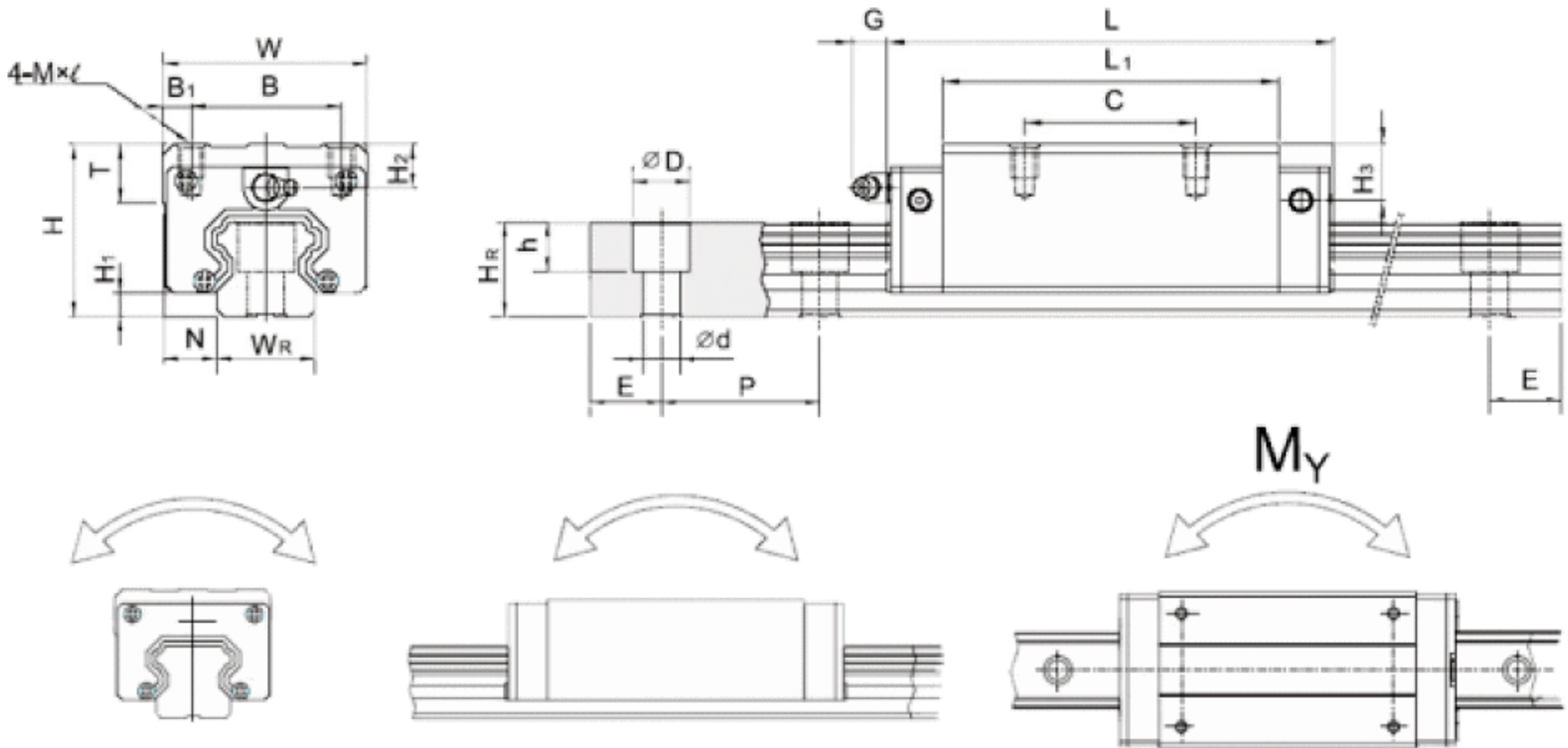

Model No.	Dimensions of Assembly (mm)			Dimensions of Block (mm)										Dimensions of Rail (mm)						Mounting Bolt for Rail (mm)	Basic Dynamic Load Rating C (kN)	Basic Static Load Rating CO (kN)	Static Rated Moment			Weight					
	H	H ₁	N	W	B	B ₁	C	L ₁	L	K ₁	K ₂	G	MxL	T	H ₂	H ₃	W _R	H _R	D				h	d	P	E	M _R (kN-m)	M _P (kN-m)	M _Y (kN-m)	Block (kg)	Rail (kg/m)
HGH 15CA	24	4.3	9.5	34	26	4	26	39.4	61.4	10	4.85	5.3	M4x5	6	7.95	7.7	15	15	7.5	5.3	4.5	60	20	M4x16	11.38	16.97	0.12	0.10	0.10	0.18	1.45
HGH 20CA	30	4.6	12	44	32	6	36	50.5	77.5	12.25	6	12	M5x6	8	6	7	20	17.5	9.5	8.5	6	60	20	M5x16	17.75	27.76	0.27	0.20	0.20	0.30	2.21
HGH 20HA							50	65.2	92.2	12.6															21.18	35.90	0.35	0.35	0.35	0.39	
HGH 25CA	40	5.5	12.5	48	35	6.5	35	58	84	16.8	6	12	M6x8	8	10	13	23	22	11	9	7	60	20	M6x20	26.48	36.49	0.42	0.33	0.33	0.51	3.21
HGH 25HA							50	78.6	104.6	19.6															32.75	49.44	0.56	0.57	0.57	0.69	
HGH 30CA	45	6	16	60	40	10	40	70	97.4	20.25	6	12	M8x10	8.5	9.5	13.8	28	26	14	12	9	80	20	M8x25	38.74	52.19	0.66	0.53	0.53	0.88	4.47
HGH 30HA							60	93	120.4	21.75															47.27	69.16	0.88	0.92	0.92	1.16	
HGH 35CA	55	7.5	18	70	50	10	50	80	112.4	20.6	7	12	M8x12	10.2	16	19.6	34	29	14	12	9	80	20	M8x25	49.52	69.16	1.16	0.81	0.81	1.45	6.30
HGH 35HA							72	105.8	138.2	22.5															60.21	91.63	1.54	1.40	1.40	1.92	
HGH 45CA	70	9.5	20.5	86	60	13	60	97	139.4	23	10	12.9	M10x17	16	18.5	30.5	45	38	20	17	14	105	22.5	M12x35	77.57	102.71	1.98	1.55	1.55	2.73	10.41
HGH 45HA							80	128.8	171.2	28.9															94.54	136.46	2.63	2.68	2.68	3.61	
HGH 55CA	80	13	23.5	100	75	12.5	75	117.7	166.7	27.35	11	12.9	M12x18	17.5	22	29	53	44	23	20	16	120	30	M14x45	114.44	148.33	3.69	2.64	2.64	4.17	15.08
HGH 55HA							95	155.8	204.8	36.4															139.35	196.20	4.88	4.57	4.57	5.49	
HGH 65CA	90	15	31.5	126	76	25	70	144.2	200.2	43.1	14	12.9	M16x20	25	15	15	63	53	26	22	18	150	35	M16x50	163.63	215.33	6.65	4.27	4.27	7.00	21.18
HGH 65HA							120	203.6	259.6	47.8															208.36	303.13	9.38	7.38	7.38	9.82	

Note: 1kgf = 9.81N

LINEAR GUIDES AND RAILS - DIMENSIONS

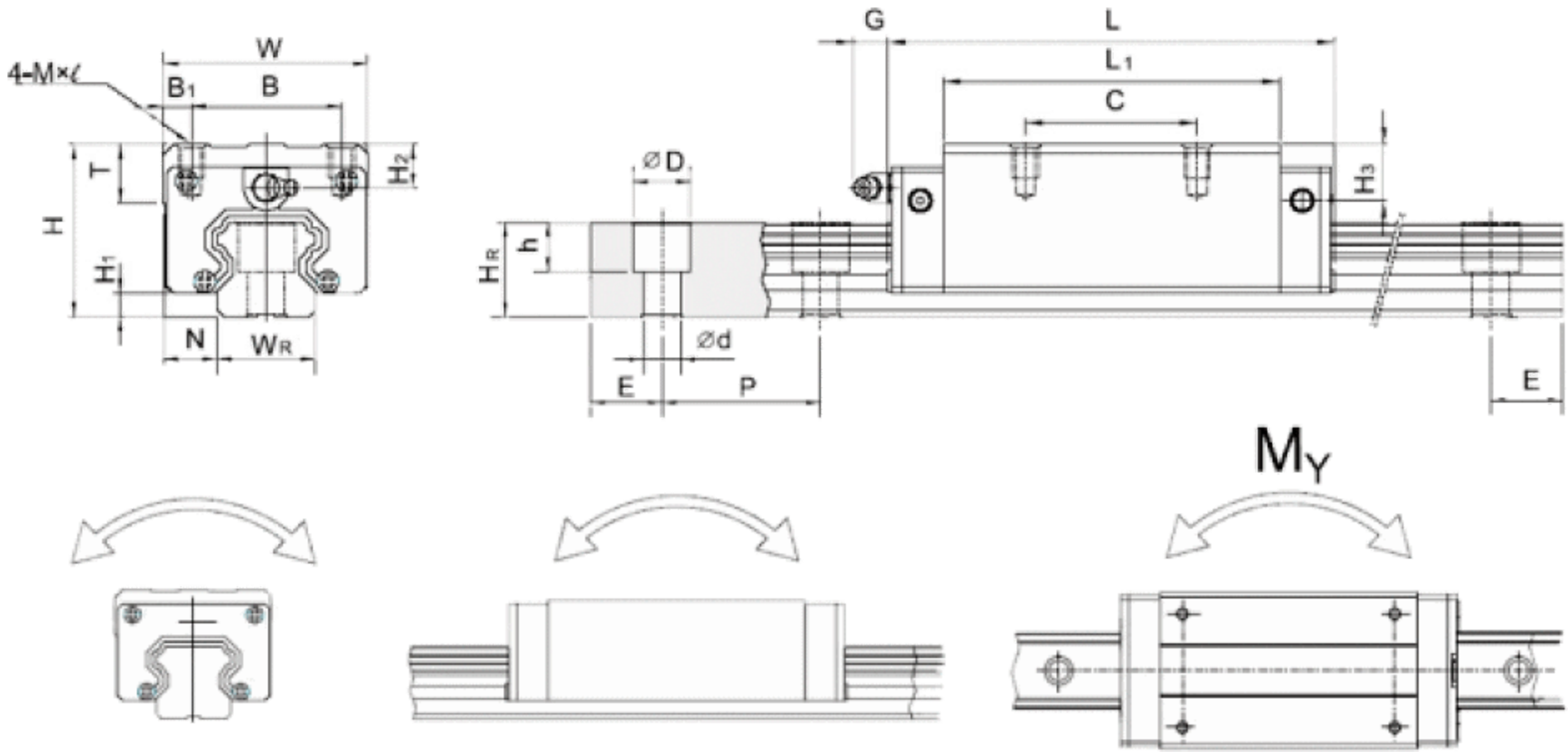

Model No.	Dimensions of Assembly (mm)			Dimensions of Block (mm)										Dimensions of Rail (mm)										Mounting Bolt for Rail (mm)	Basic Dynamic Load Rating C (kN)	Basic Static Load Rating CO (kN)	Static Rated Moment			Weight	
	H	H ₁	N	W	B	B ₁	C	L ₁	L	K ₁	K ₂	G	MxL	T	H ₂	H ₃	W _R	H _R	D	h	d	P	E				M _R (kN-m)	M _P (kN-m)	M _Y (kN-m)	Block (kg)	Rail (kg/m)
HGH 15CA	24	4.3	16	47	38	4.5	30	39.4	61.4	8	4.85	5.3	M5	6	7.95	7.7	15	15	7.5	5.3	4.5	60	20	M4x16	11.38	16.97	0.12	0.10	0.10	0.17	1.45
HGH 20CA	30	4.6	21.5	63	53	5	40	50.5	77.5	10.25	6	12	M6	8	6	7	20	17.5	9.5	8.5	6	60	20	M5x16	17.75	27.76	0.27	0.20	0.20	0.40	2.21
HGH 20HA								65.2	92.2	17.6															21.18	35.90	0.35	0.35	0.35	0.52	
HGH 25CA	36	5.5	23.5	70	57	6.5	45	58	84	11.8	6	12	M8	8	6	9	23	22	11	9	7	60	20	M6x20	26.48	36.49	0.42	0.33	0.33	0.59	3.21
HGH 25HA								78.6	104.6	22.1															32.75	49.44	0.56	0.57	0.57	0.80	
HGH 30CA	42	6	31	90	72	9	52	70	97.4	14.25	6	12	M10	8.5	6.5	10.8	28	26	14	12	9	80	20	M8x25	38.74	52.19	0.66	0.53	0.53	1.09	4.47
HGH 30HA								93	120.4	25.75															47.27	69.16	0.88	0.92	0.92	1.44	
HGH 35CA	48	7.5	33	100	82	9	62	80	112.4	14.6	7	12	M10	10.1	9	12.6	34	29	14	12	9	80	20	M8x25	49.52	69.16	1.16	0.81	0.81	1.56	6.3
HGH 35HA								105.8	138.2	27.5															60.21	91.63	1.54	1.40	1.40	2.06	
HGH 45CA	60	9.5	37.5	120	100	10	80	97	139.4	13	10	12.9	M12	15.1	8.5	20.5	45	38	20	17	14	105	22.5	M12x35	77.57	102.71	1.98	1.55	1.55	2.79	10.41
HGH 45HA								128.8	171.2	28.9															94.54	136.46	2.63	2.68	2.68	3.69	
HGH 55CA	70	13	43.5	140	116	12	95	117.7	166.7	17.35	11	12.9	M14	17.5	12	19	53	44	23	20	16	120	30	M14x45	114.44	148.33	3.69	2.64	2.64	4.52	15.08
HGH 55HA								155.8	204.8	36.4															139.35	196.20	4.88	4.57	4.57	5.96	
HGH 65CA	90	15	53.5	170	142	14	110	144.2	200.2	23.1	14	12.9	M16	25	15	15	63	53	26	22	18	150	35	M16x50	163.63	215.33	6.65	4.27	4.27	9.17	21.18
HGH 65HA								203.6	259.6	52.8															208.36	303.13	9.38	7.38	7.38	12.89	

Note: 1kgf = 9.81N



BLUE BRONZE NUT GREASE

LONG LIFE MULTI-PURPOSE GREASE

Appearance	Smooth, blue grease
Worked penetration	290-320
Base type	Severely refined mineral oil
Thickener	Multi-complex soap technology
Temperature range	-30°C to 150°C
Base fluid viscosity at 40°C	180 cSt
Base fluid viscosity at 100°C	17 cSt
Shell 4 ball (IP 239)(ASTMD2596) Weld load	>800 kg
Mean hertz load	120 kg
Timken 'OK' Load	60lb
(IP 326)(ASTMD2509) Copper Corrosion test	1 a
(IP 112)(ASTMD130) Corrosion test - Emcor (IP 220)	0:0
Water Washout Test (IP 215)(ASTMD1264)	2%

STORAGE

Storage temperature should be controlled to between 1 and 40°C.
Designed for the effective lubrication and protection of all types of Abszac bronze nuts.

FEATURES

Temperature range -30°C to 150°C.
Revolutionary multi-complex soap technology.
Greatly extended lubrication intervals typically 3 times longer than conventional soap thickened greases.
Good corrosion resistance.
Blue in colour for high visibility.

DIRECTIONS FOR USE

Apply manually.
Compatible with other soap thickened greases.
However, for best results, the previous lubricant should be removed prior to application.

Please call us for a quotation.



COPYRIGHT

"ABSSAC" is a registered trade mark 2375859

All rights are reserved.

The use of this catalogue is made available to you by Abszac Limited. The exclusive right to control the use of the copyright and trademarks on this site is controlled by Abszac Limited. These may not be copied, reproduced, published, distributed, modified or otherwise used in any form including electronic copying without the express permission of Abszac Limited. Abszac Limited has made all reasonable endeavor to ensure that the material on this site is accurate. You agree that Abszac Limited, nor any other person involved in creating or providing this catalogue shall be liable for any indirect or consequential damage arising from the use of any information contained in this catalogue.

The information contained in this catalogue is provided 'as is' without warranty of any kind, either expressed or implied. Abszac Limited assumes no responsibility for errors or omissions in this catalogue or other documents which are reference by or linked to this catalogue. This catalogue could include technical or other inaccuracies including typographical errors. Updates and changes are periodically added to the information herein; these changes will be incorporated in new editions of this catalogue. Abszac Limited may make improvements and/or changes in the product(s) or service(s) described in this publication at any time. You agree that the above terms represent the entire basis of the agreement between us, upon which you are permitted to enter this site and you agree that all relations between us are subject to the Law of England and Wales.



STANDARD CONDITIONS OF SALE

1. Interpretation
 - 1.1 In these Conditions:

"Buyer" means the person who accepts a quotation of the Seller for the sale of the Goods or whose order for the Goods is accepted by the Seller

"Goods" means the goods (including any instalment of the goods or any parts for them) which the Seller is to supply in accordance with these Conditions

"Seller" means ABSSAC LIMITED a company incorporated in England and whose registered number is 1677177.

"Conditions" means the standard terms and conditions of sale set out in this document and (unless the context otherwise requires) includes any special terms and conditions agreed in writing between the Buyer and the Seller

"Contract" means the Contract for the purchase and sale of the Goods

"Writing" includes telex, cable, facsimile transmission, E-Mail and comparable means of communication
 - 1.2 Any reference in these Conditions to any provision of a statute shall be construed as a reference to that provision as amended, re-enacted or extended at the relevant time
 - 1.3 The headings in these Conditions are for convenience only and shall not affect their interpretation
2. Basis of the sale
 - 2.1 Subject to Condition 3 below, the Seller shall sell and the Buyer shall purchase the Goods in accordance with any oral or written order of the Buyer which is accepted by the Seller, or any written quotation of the Seller which is accepted by the Buyer, subject to these Conditions which shall govern the Contract to the exclusion of any other terms and conditions subject to which any such quotation is accepted or purported to be accepted, or any such order is made or purported to be made, by the Buyer
 - 2.2 No variation, addition or waiver of any of these Conditions shall be effective unless it is in Writing and signed by a duly authorised representative of both the Seller and the Buyer
 - 2.3 The Seller's employees or agents are not authorised to make any representations concerning the Goods unless confirmed by the Seller in Writing. In entering into the Contract the Buyer acknowledges that it does not rely on any such representations which are not so confirmed
 - 2.4 Samples supplied and advice or recommendations as to storage, application or use of the Goods given by the Seller or its employees or agents to the Buyer or its employees or agents are for guidance only and any such matter which is not confirmed in Writing by the Seller is followed or acted upon entirely at the Buyer's own risk and accordingly the Seller shall not be liable for any such advice or recommendation which is not so confirmed then the Buyer should depend on their accuracy only after obtaining specific written confirmation to that effect from the Seller
 - 2.5 Any typographical, clerical or other error or omission in any sales literature, quotation, price list, acceptance of offer, invoice or other document or information issued by the Seller shall be subject to correction without any liability on the part of the Seller
3. Quotations and acceptance of orders
 - 3.1 Quotations issued by the Seller are invitations to order Goods from the Seller. No Contract will exist until the Seller has accepted the Buyer's order in accordance with condition 3.3.
 - 3.2 Subject to condition 3.1 the price in the quotation should be valid for a period of 30 days from the date of the quotation unless otherwise advised by the Seller in Writing
 - 3.3 The Seller shall not be bound by any order submitted by the Buyer unless and until confirmed by the Seller in Writing
 - 3.4 Scheduled call off purchase orders made by the Buyer with the Seller are for twelve month periods only, or until 19th December of that year, depending which comes first unless otherwise agreed in Writing by the Seller
 - 3.5 The Buyer is committed to purchasing any remaining amount of products on his purchase order if the Buyer decides to cancel the order mid schedule unless otherwise agreed in Writing by the Seller
- 3.6 No order which has been accepted by the Seller may be cancelled by the Buyer except with the agreement in Writing of the Seller on the terms that the Buyer shall indemnify the Seller in full against all loss (including loss of profit), costs (including the costs of all labour and materials used), damages, charges and expenses incurred by the Seller as a result of cancellation.
- 3.7 Compliance with United States Export Regulations

It is Absac's policy to request, if applicable, the end use and end user details in all sales and repairs of USA origin products and in all transfers of technical data or software to ensure compliance with applicable u.s. export control laws and regulations. Because the products you are purchasing may be used outside of the United States, we will need confirmation of the following from the (buyer). It is on the onus of the buyer to ensure that Absac is informed of the following information.

 - 1.1 (Buyer) will not export or re-export any USA origin products, technology or software to Cuba, Iran, Iraq, Libya, North Korea, Sudan, or Syria, unless otherwise authorized by the United States Government.
 - 2.1 (Buyer) will not sell, transfer, export or re-export any USA origin products for use in activities which involve the development, production, use or stockpiling of nuclear, chemical or biological weapons or missiles, nor use USA origin products in any facilities which are engaged in activities relating to such weapons.
 - 3.1 (Buyer) acknowledge that u.s. law prohibits the sale, transfer, export or re-export or other participation in any export transaction involving USA origin products with individuals or companies listed in the u.s. Commerce Department's Table of Denial Orders, the u.s. Treasury Department's list of Specially Designated Nationals or the u.s. Department of State's list of individuals debarred from receiving Munitions List items.
 - 4.1 (Buyer) will abide by all applicable u.s. export control laws and regulations for any products purchased from USA origin products, software or technology.
 - 5.1 (Buyer) agree that the export control requirements in No. 1-4 above shall survive the completion, early termination, cancellation or expiration of the applicable purchase order, agreement or contract.
4. Specifications
 - 4.1 The Buyer shall be responsible to the Seller for ensuring the accuracy of the terms of any order (including any applicable specification) submitted by the Buyer, and for giving the Seller any necessary information relating to the Goods within a sufficient time to enable the Seller to perform the Contract in accordance with its terms
 - 4.2 The quantity, quality and description of any specification for the Goods shall be those set out in the Seller's quotation (if accepted by the Buyer) or the Buyer's order (if accepted by the Seller)
 - 4.3 If Goods are supplied in accordance with the Buyer's specifications the Buyer shall be solely responsible for the specifications and ensuring that they are accurate
 - 4.4 If any technical calculations are made by the Seller using information supplied by the Buyer the Buyer accepts that they are responsible for supplying accurate technical information and accordingly the Seller is not liable in respect of calculations based on incorrect information given
 - 4.5 If Goods are to be manufactured or any process is to be applied to the Goods by the Seller in accordance with a specification or request submitted by the Buyer or should any change be made to the Goods at the request of the Buyer the Buyer shall indemnify the Seller against all loss damages costs and expenses awarded against or incurred by the Seller in connection with or paid or agreed to be paid by the Seller in settlement of any claims for infringement of any patent, copy right, design, trade mark or other industrial or intellectual property rights of any person which results from the Seller's use of the Buyers specification

- 4.6 The Seller reserves the rights to make any changes in the specification of the Goods which are required to conform with any applicable statutory or EC requirements or, where the Goods are to be supplied to the Seller's specification, which do not materially affect their quality or performance
- 4.7 At all times the buyer has the responsibility to adequately guard and maintain the product supplied in accordance with relevant operation manuals, service factors and health and safety legislation applicable for any product supplied by ABSSAC Limited.
- 4.8 The seller (Abszac Limited) shall not in any event be liable for any consequential damages, secondary charges, expenses for installing or disconnecting, or losses or injuries to persons or property resulting from any alleged defect in the product or any use of the product, and in manner that exceeds its design, duty cycle and or ability.
- 4.9 It remains the responsibility of the buyer to test any samples or other products that the seller will provide for fatigue, stress and general ability in the application. All products that the seller provides and are used in both real and test situations are considered by Abszac Ltd to have been thoroughly tested to meet and exceed the anticipated life and duty requirement of the product in its application by the buyer. It remains the responsibility of the buyer to give all technical information to the seller and all buyers are responsible for meeting health and safety measures and adequately guarding users and all associated parties against all and any possible failures in line with the health and safety requirements.
Other Where recommended guidelines of serviceable or replaceable parts and maintenance/inspection requirements are exceeded or ignored by the user and/or buyer, no warranty or other claim can or will exist. Where minimum or maximum values/sizes/limits/dimensions/fitting instructions and technical data of parts are ignored/abused/extended/not applied/not actioned or used in excess of the design or standard parameters of the product by the user and/or buyer then no warranty claim or other claim can exist.
No warranty or other claim can exist or be made by the user or buyer or other to the seller or its agent or other for any part used in motor sport, military or aviation. No warranty is given to this type of application.
All or any secondary or further processes/disassembly/machining/ heating/drying/coating or any other additional process the originally supplied product or associated part/product after dispatch from the seller or its agent voids any warranty claim or other claim.
It remains the responsibility of the buyer or user to advise us the seller of any and all certification/test/traceable certification requirement.
Conversations may be recorded as part of our ongoing customer service program.
5. Packaging
- 5.1 Packaging for the Goods shall be at the discretion of the Seller which has the right to pack the Goods in such a manner and with such materials and in such quantities as in his absolute discretion thinks fit unless detailed packaging instructions are received from the Buyer prior to agreeing a price for the Goods which the Seller agrees to in Writing
6. Price of the Goods
- 6.1 Price of the Goods shall be the Seller's quoted price or, where no price has been quoted (or a quoted price is no longer valid) the price listed in the Seller's published price list current at the date of acceptance of this order. Where the Goods are supplied for export from the United Kingdom, the Seller's published export price list shall apply. All prices quoted are valid for 30 days only or until earlier acceptance by the Buyer, after which time they may be altered by the Seller without given giving written notice to the Buyer
- 6.2 The price is exclusive of any applicable value added tax, which the Buyer shall be additionally liable to pay to the Seller
- 6.3 All prices stated shall be subject to variation at the sole discretion of the Seller at any time without prior notice and the Seller shall notify the Buyer of any variation before delivery of the Goods
7. Payment
- 7.1 Liability for payment for the Goods supplied to customers who have a trading account with the Seller shall arise on delivery and payment in cash is due 30 days from the date of the invoice or as otherwise specifically agreed in Writing by the Seller. Payment shall be due and the company shall be entitled to sue for the price whether or not property in the Goods has passed by virtue of condition 10 and notwithstanding the delivery may not have taken place as a result of the Buyer's wrongful or refusal to accept delivery. The time of payment of the price shall be of the essence of the Contract
- 7.2 Liability for payment for the Goods supplied on a proforma invoice basis for customers who do not have a trading account with the Seller shall be prior to delivery of the Goods. The time of payment of the price shall be of the essence of the Contract. It is the Buyer's responsibility to give written notice to the Seller of any payment under proforma invoice arrangements
- 7.3 Sums paid after the due date shall pay interest until the day payment is received at the rate of 5% per annum above the base rate from time to time of National Westminster Bank Plc occurring from day to day from the date of delivery until the date of payment in full
- 7.4 If the recovery of sums outstanding from the Buyer is passed to a debt collection agency the Buyer shall pay the Seller's costs in instructing the said debt collection agency and all ancillary legal costs
- 7.5 Without prejudice to any other rights or remedies of the Seller any in default of the Buyer in making payment on the due date shall entitle the Seller to suspend deliveries under the Contract or any other Contract so long as the default continues and break the Contract as repudiated by the Buyer and determined if the Buyer has not within 14 days of receiving written notice from the Seller paid all sums due to the Seller.
8. Delivery
- 8.1 Delivery shall take place when the Goods are unloaded at or delivered to the Buyer's premises or other delivery location agreed between the Seller and the Buyer except that if the Buyer collects or arranges collection of the Goods from the Seller's premises, or nominates a carrier for the Goods delivery shall take place when the Goods are loaded on the collection or carriers vehicle
- 8.2 Any dates quoted for delivery of the Goods are approximate only and the Seller will not be liable for any delay in delivery of the Goods however so caused. Time for delivery shall not be of the essence of the Contract unless previously agreed by the Seller in Writing. The Goods may be delivered by the Seller in advance of the quoted delivery date upon giving responsible notice to the Buyer
- 8.3 The Buyer shall accept immediate delivery or arrange to collect the Goods or arrange suitable storage, failing which the company may either:
- 8.3.1 effect delivery by whatever means they think most appropriate; or
- 8.3.2 arrange storage at the Buyer's risk and expense pending delivery; or
- 8.3.3 re-sell or otherwise dispose of the Goods without prejudice to any other rights the Seller may have against the Buyer for breach of Contract or otherwise
- 8.4 Where the agreement provides for delivery by instalments each delivery shall constitute a separate Contract and failure by the Seller to deliver any one or more of the instalments in accordance with these Conditions or any claim by the Buyer in respect of any one or more instalments shall not entitle the Buyer to treat the Contract as a whole as repudiated
- 8.5 The Buyer shall not be entitled to reject the Goods by reason only of short delivery

- 8.6 The quantity of the Goods delivered under the Contract shall be recorded by the Seller upon dispatch from the Seller's factory or warehouse and the Seller's records shall be accepted by the Buyer as conclusive evidence of the quantity delivered.
- 8.7 It is the Buyer's responsibility to notify the seller if Goods have not been received by the Buyer within seven days of the date of receipt of the Seller's invoice, therefore, if no notification is made the Buyer shall be deemed to have received the Goods.
- 8.8 If the Seller fails to deliver the Goods (or any instalment) for any reason other than any cause beyond the Seller's reasonable control or the Buyer's fault, and the Seller is accordingly liable to the Buyer, the Seller's liability shall be limited to the excess (if any) of the cost to the Buyer (in the cheapest available market) of similar Goods to replace those not delivered over the price of the Goods. The seller is under no obligation or liability in respect of failure to complete or delay or failure to deliver the goods comprised in any order or contract caused directly or indirectly by act of war or terrorism, strikes, lockouts, labour troubles, breakdowns, delays in transport, accidents, delay in obtaining material, fire, government prohibition, delivery of necessary fuel requirements, any and all problems or other restrictions relating to design or other manufacturing difficulties that arise during an order.
- 8.9 If the Buyer fails to take delivery of the Goods or fails to give the Seller adequate delivery instructions at the time stated for delivery (otherwise than by reason of any cause beyond the Buyer's reasonable control or by reason of the Seller's fault) then, with out prejudice to any other right or remedy available to the Seller, the Seller may:
- 8.9.1 store the Goods until actual delivery and charge the Buyer for the reasonable costs (including insurance) of storage;
or
- 8.9.2 sell the Goods at the best price readily obtainable and (after deducting all reasonable storage and selling expenses) account to the Buyer for the excess over the price under the Contract or charge the Buyer for any shortfall below the price under the Contract
9. Examinations and claims
- 9.1 The Buyer shall upon delivery examine the Goods and shall promptly (but in any event within seven working days of delivery) notify in Writing the Seller and the carrier, where relevant, of any apparent damage defect or shortage.
- 9.2 The Buyer shall comply with the carriers rules, regulations and requirements so as, when appropriate, to the Seller to make a claim against the carrier in respect of any damage or loss in transit.
- 9.3 Claims in respect of damage defects or shortage not apparent on examination and under clause 9.1 must be notified in Writing to the Seller within 7 days of the date of delivery
- 9.4 Notification under clauses 9.1 to 9.3 above shall be first made by telephone then by notice in Writing delivered by facsimile transmission or by first class recorded delivery mail and addressed to Abssac Limited Units 19/20 Bond Industrial Estate Wickhamford Evesham Worcs WR11 7RH.
- 9.5 In default of such notification the seller shall be deemed conclusively to have properly preformed its obligations under the Contract.
10. Property and risk
- 10.1 All risk including that of dam age to or loss of the Goods shall pass to the Buyer:
- 10.1.1 at the time when the Seller notifies the Buyer that the Goods are available for collection the case of Goods to be supplied at the Seller's premises
or
- 10.1.2 at the time of delivery but prior to unloading or if the Buyer wrongfully fails to take delivery of the Goods at the time when the Seller has tendered to delivery of the Goods in the case of Goods to be supplied otherwise than at the Seller's premises
or;
- 10.1.3 at the time of delivery of the Goods to a carrier for delivery to the Buyer in the case of Goods to be supplied in a manner otherwise than as set out in Conditions 10.1.1 or 10.1.2 above
- 10.2 The Buyer shall fully insure the Goods against all risks from the times stipulated for the passing of risk in condition 10.1 above up to the time when the proprietary rights in such Goods pass to the Buyer
- 10.3 Property (both legal and beneficial) in the Goods shall remain in the company until all sums owing to the Seller whether under the Contract or any other Contract at any time between the Seller and the Buyer made prior to the date of the Contract ("the Indebtedness) shall have been paid in full, until such time the Buyer shall hold the Goods as bailee for the Seller
- 10.4 The Buyer shall not be entitled to pledge or in any way charge by way of security for any indebtedness any of the Goods which remain the property of the Seller, but if the Buyer does so all moneys owing by the Buyer to the Seller shall (without prejudice to any other right or remedy of the Seller) forthwith become due and payable
- 10.5 The Buyer until otherwise notified by the Seller or on the happening of any of the event specified in Condition 10.7 ("the Events") may in the ordinary course of business sell the Goods and pass property in them ("the Re-Sale") subject to the stipulations ("the Stipulations") imposed in Condition 1 0.5
- 10.6 The Stipulations are that until the Indebtedness has been fully discharged;
- 10.6.1 the Goods shall not be converted into any other product or mixed with any other Goods to make another product ("the New Product") nor will the Buyer sell the New Product and property in it ("the Sale") but if the Buyer in breach of the above provision does convert or mix the Goods property in the New Product shall at the earliest moment that such vesting is possible, vest and remain in the Seller whether or not property in the Goods is at the moment extinguished
- 10.6.2 the Re-Sale shall be for the account of the Seller and, unless the Seller by written notice requires the payment to it of the proceeds of the Re-Sale ("the Proceeds") to the extent of the Indebtedness, in which case the Buyer shall forthwith on receipt of such notice or as soon as thereafter as it shall receive the Proceeds makes its payment, the Buyer shall retain the Proceeds in a separate bank account to the order of the Seller and not mix them with any other monies
- 10.6.3 in the event of a breach by the Buyer of its obligations under additions 10.6.1 the Seller shall have the right to trace the Proceeds in to any other moneys which may have been mixed and the Buyer shall indemnify the Seller on a full indemnity basis against loss, damage, costs or expenses incurred in such tracing
- 10.6.4 until the Re-Sale the Seller has have the right to repossess the Goods or take possession of the New Product at any time and for this purpose shall have the right to enter on to any premises or land in the ownership or possession of the Buyer and remove the Goods and/or the New Product notwithstanding that they are affixed to such premises or land and the Buyer shall indemnify the Seller on a full indemnity basis against all loss, damage, costs or expenses so arising including loss, damage, costs or expenses in respect of third party claims. Such taking of possession re delivery shall be without prejudice in the obligation of the Buyer to purchase Goods
- 10.6.5 the Goods and the New Product shall until their Re-Sale or Sale be stored separately, protected and insured and identified and clearly marked as the Seller's property
- 10.7 The Events are;
- 10.7.1 The giving of any notice to the Buyer that a receiver, manager, administrative receiver, supervisor, nominee or administrator is to be or has been appointed over any of the property or assets of the Buyer or that a petition to wind up the Buyer is to be or has been presented or that an application for an administration order is to be or has been made or any notice of a resolution to wind up the Buyer (say for the purposes of bona fide reconstruction or amalgamation)
- 10.7.2 A decision by the Buyer that the Buyer intends to make any arrangement or composition with its creditors generally.
- 10.7.3 Where the Buyer pursuant to section 123 or 268 of the Insolvency Act 1986 appears to be unable to pay a debt or appears to have no reasonable prospects of being able to pay a debt

- 10.7.4 any distress or execution levied as threatened to be levied on any property or assets of the Buyer
- 10.7.5 the inability of the Buyer to pay its debts as they fall due
- 10.7.6 on receipt of notification from the company under Condition 10.5 or on the happening of any of the Events the Buyer shall immediately deliver the Goods and the New Product property in which the Product is reserved to or is vested in the Seller to such address as the Seller shall specify in default of which or in the alternative, the Seller shall have the right to enter on any premises or land in the ownership or possession of the Buyer in order to recover the Goods and the New Product and the Buyer shall indemnify the Seller on a full indemnity basis against all loss, damage, costs or expenses as arising including loss, damage, cost or expenses in respect of third party claims
11. Breach by or insolvency by the Buyer
- 11.1 if the Buyer shall not comply with any of its obligations to the Seller or upon the occurrence of any of the Events referred to in clause 10.7 the Seller shall have the right forthwith to terminate the Contract but without affecting any other claim right or remedy of the Seller against the Buyer and without any liability to the Buyer, and if the Goods have been delivered but not paid for the price shall become immediately due and payable notwithstanding any previous agreement or arrangement to the contrary
12. Export Terms
- 12.1 In these Conditions "Incoterms" mean the international rules for the interpretation of trade terms of the International Chambers of Commerce as in force at the date when the Contract is made. Unless the Context otherwise requires, any term or expression which is defined in or given a particular meaning by the provisions Incoterms shall have the same meaning in these Conditions, but if there is any conflict between the provisions of Incoterms and these Conditions, the latter shall prevail
- 12.2 Where the Goods are supplied for export from the United Kingdom, the provisions of this clause 12 shall (subject to any special terms agreed in Writing between the Buyer and the Seller) apply notwithstanding any other provision of these Conditions
- 12.3 The Buyer shall be responsible for complying with any legislation or regulations governing the importation of the Goods in to the country or destination and for the payment of any duties on them
- 12.4 Unless otherwise agreed in Writing between the Buyer and the Seller, the Goods shall be delivered fob the air or sea port of shipment and the Sellers shall be under no obligation to give notice under section 32(3) of the Sale Of Goods Act 1979
- 12.5 The Buyer shall be responsible for arranging for testing and inspection of the Goods at the Sellers premises before shipment. The Seller shall have no liability for any claim in respect of any defect in the Goods which would be apparent on inspection and which is made after shipment, or in respect of any damage during transit
- 12.6 Payment of all amounts due to the Seller shall be made by irrevocable letter of credit opened by the Buyer in favour of the Seller and confirmed by a bank acceptable by the Seller, or by telegraphic transfer in to the Sellers aforementioned bank account or if the Seller agrees in Writing on or before acceptance of the Buyer order to waive this requirement, by acceptance by the Buyer and delivery to the Seller of a bill of exchange drawn on the Buyer payable 60 days after sight of the order to the Seller at such branch of National Westminster Bank in England as may be specified in the bill of exchange
- 12.7 Unless otherwise specifically agreed between the Seller and the Buyer all Exports sales shall be made by delivery to the Buyer's premises and the Seller's prices shall be increased to cover the Seller's costs in making such deliveries
- 12.8 The Buyer warrants that if an import licence or permit is required for the importation of the Goods into the county or destination then such import licence or permit has been obtained or would be obtain prior to shipment
13. Cancellation, suspension and termination
- 13.1 If the Buyer shall purport to cancel the whole or any part of the Contract the Seller may by notice in Writing to the Buyer elect to treat the Contract as repudiated and the Buyers shall thereupon be liable to pay the Seller by way of liquidated damages a sum equal to all the expenses incurred by the Seller in connection with the Contract including an appropriate amount in respect of administration overheads, costs and loss of profit. The Sellers reasonable estimate of the expenses incurred shall be final and binding on the parties
- 13.2 If for any cause whatsoever beyond its control the Seller is unable to make any delivery on the applicable delivery date or preform any of its obligations under the Contract the Seller may be notice in Writing to the Seller terminate the Contract or suspend the Contract without liability of any loss or damage thereby occurred by the Buyer
14. Intellectual property
- 14.1 The Buyer shall not infringe any patent, trade name, registered design, copyright industrial or other intellectual property right belonging to the Seller in relation to the Goods or any other goods or matters supplied by the Seller with or in relation to the Goods
- 14.2 The Buyer shall promptly report to the Seller particulars of any use by any person of a patent, trade name, registered design, trade mark or get up of Goods which might amount to infringement of any patent, trade mark, registered design, copy right, industrial or other intellectual property right attaching to the Goods or to unfair competition on passing off
- 14.3 In the event that it comes to the notice of the Buyer that any person alleges that a patent, trade name, registered design, copy right, industrial or other intellectual property right is invalid or that they infringe any rights of that person or that they are open to any form of attack the Buyer shall not make any omissions but shall promptly report the matter to the Seller
- 14.4 The Seller shall have conduct of all proceedings relating to any patent, trade name, registered design, copy right, industrial or other intellectual property right attaching to the Goods
15. Force majeure
- 15.1 In so far as the performance of the Contract by the Seller may be affected by any strike, any lack of available, shipping or transport or materials, any restriction regulation or decree by any local or municipal authority or government department or by any cause beyond the Seller's reasonable control (which shall be construed without reference to the proceeding causes) the Seller may elect at its absolute discretion either;
- 15.1.1 to terminate the Contract or;
- 15.1.2 to proceed to preform or continue performance under the Contract within a reasonable time after the termination of such events of circumstance
- 15.2 In the event that the Seller makes an election under clause 15.1 the Buyer shall accept the Goods or such part of them as are delivered to it notwithstanding any delay
16. Exclusion of Contract (rights of the third party) Act 1999
- 16.1 Nothing in these Conditions will confer on any third party any benefit or the right to enforce any terms of these Conditions
17. Proper law
- 17.1 The Contract is and shall be deemed to be made in England and shall in all respects be governed by English Law and shall be subject to the non-exclusive jurisdiction of the English Court General
18. General
- 18.1 Any notice required or permitted to be given by either party to the other under these Conditions shall be in Writing and addressed to that other party at its registered office or principal place of business or such other address as may at the relevant time having been notified pursuant to this provision to the party giving the notice

- 18.2 No waiver by the Seller of any breach of the Contract by the Buyer shall be considered as a waiver of any subsequent breach of the same or any other provision
- 18.3 If any provision of these Conditions is held by any competent authority to be invalided or unenforceable in whole or in part the validity of the other provisions of these Conditions and the remainder of the provision in question shall not be affected
- 18.4 No liability, warranty or any other claim can or will exist for any product(s) during or as a consequence of or any consequence whatsoever resulting directly or indirectly from or in connection with any of the following regardless of any other contributory cause or event from :
- Terrorism Terrorism is defined as any act or acts including and not limited to the use or threat of force/violence/harm or damage to life or property or the threat of such harm or damage including harm or damage by nuclear and or chemical and or biological and or radiological means. Caused or occasioned by any persons or groups or so claimed in whole or in part for political religious ideological or similar purposes. Or, any action taken in controlling preventing suppressing or in anyway relating to the above.
- War War or invasion, act of foreign enemy hostilities of a warlike operation or operations (whether war be declared or not) civil war rebellion revolution insurrection civil commotion assuming the proportions of or amounting to an uprising military or usurped power. Or any action taken in controlling preventing suppressing or in any way relating to any of the above.
- 18.5 Any dispute arising under or in connection with these Conditions or the sale of the Goods shall be referred to arbitration by a single arbitrator appointed by agreement or (in default) nominated on the application of either party by the president for the time being of the Law Society.
- Absac Limited may make changes to the contents/ improvements and/or changes in the product(s) or service(s) described in this publication at any time.

August 2013.