

SWBS Compact Double Nut



ABSSAC

PRECISION MOTION SINCE 1982

Precision Ball Screws

Sleeve type Double Nut

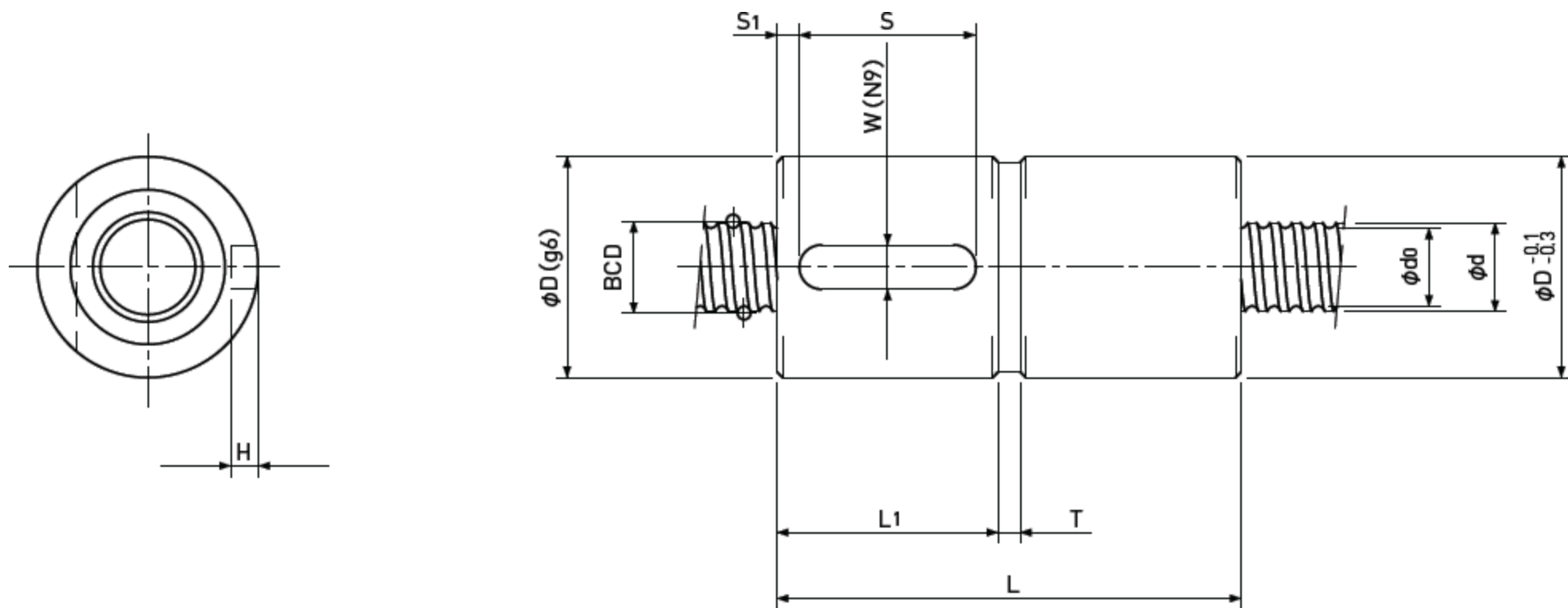

Unit : mm

Ball Nut Model number	Shaft nominal dia. d	Lead	Ball size	BCD	Lead angle	Root dia. d ₀	Number of Circuit	Basic Load Rating N		Nut Rigidity N/μm
								Dynamic Ca	Static Coa	
SWBS 0602 A	6	2	1	6.2	5°52'	5.1	2.7□×1	750	1200	114
SWBS 0602 B	6	2	1	6.2	5°52'	5.1	3.7□×1	980	1600	155
SWBS 0602.5 A	6	2.5	1	6.2	7°19'	5.1	2.7□×1	750	1200	115
SWBS 0802 A□(1□)	8	2	1	8.2	4°26'	7.1	2.7□×1	850	1600	144
SWBS 0802 B□(1□)	8	2	1	8.2	4°26'	7.1	3.7□×1	1100	2200	195
SWBS 0802 A□(2□)	8	2	1.5875	8.3	4°23'	6.6	2.7□×1	1850	3000	162
SWBS 0802 B□(2□)	8	2	1.5875	8.3	4°23'	6.6	3.7□×1	2400	4100	217
SWBS 0802.5 A	8	2.5	1.5875	8.3	5°29'	6.6	2.7□×1	1850	3000	161
SWBS 0802.5 B	8	2.5	1.5875	8.3	5°29'	6.6	3.7□×1	2400	4100	219
SWBS 0803 A	8	3	2	8.3	6°34'	6.2	2.7□×1	2600	4200	167
SWBS 0803 B	8	3	2	8.3	6°34'	6.2	3.7□×1	3500	5700	227

Ball Nut Model number	Nut dimension							
	D	L	L ₁	T	W	H	S	S ₁
SWBS 0602 A	15	33	15.5	2	3	1.8	10	2.5
SWBS 0602 B	15	38	18	2	3	1.8	12	3
SWBS 0602.5 A	15	33.5	15.5	2.5	3	1.8	10	3
SWBS 0802 A□(1□)	16	31	14.5	2	3	1.8	10	2.5
SWBS 0802 B□(1□)	16	38	18	2	3	1.8	12	3
SWBS 0802 A□(2□)	20	37	17.5	2	4	2.5	12	2.5
SWBS 0802 B□(2□)	20	42	20	2	4	2.5	16	2
SWBS 0802.5 A	20	41.5	19.5	2.5	4	2.5	12	3.5
SWBS 0802.5 B	20	47	22.5	2	4	2.5	16	3
SWBS 0803 A	20	46	22	2	4	2.5	16	3
SWBS 0803 B	20	53	25.5	2	4	2.5	20	3

- Note 1) The diameter of one of the Screw Shaft ends must be less than the Screw Shaft Root diameter, otherwise Ball Nut cannot be installed.
- Note 2) Ball Nut dimension is without seal at both ends.
If the seals are required, Ball Nut dimension should be changed, in that case, please ask ABSSAC.
Some type of Ball Nuts cannot equip with seals, please ask ABSSAC representative.
- Note 3) Rigidity
The Rigidity values shown in the table are theoretical values calculated from the amount of Elastic Displacement under the Preload equivalent to 10% of the Basic Dynamic Load Rating Ca.
- Note 4) All models are Right-hand screw. If Left-hand screw is required, please ask ABSSAC representative.

Sleeve type Double Nut

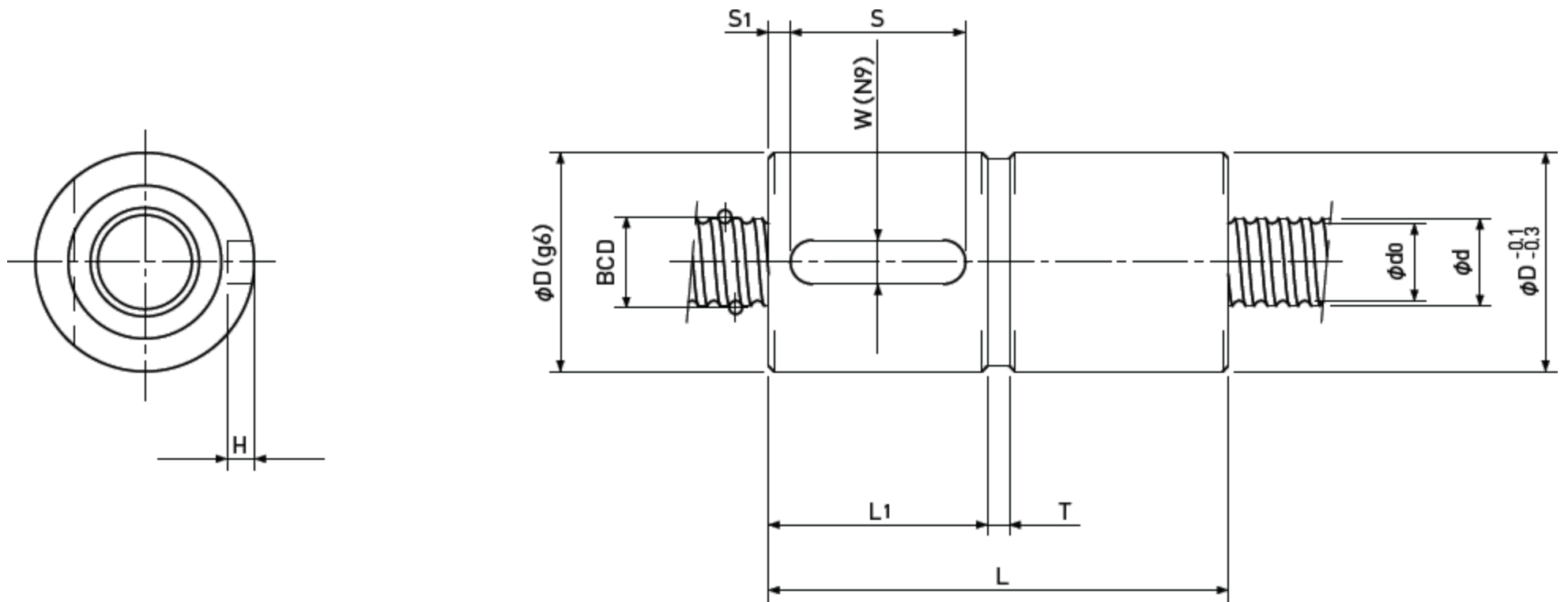

Unit : mm

Ball Nut Model number	Shaft nominal dia. d	Lead	Ball size	BCD	Lead angle	Root dia. d ₀	Number of Circuit	Basic Load Rating N		Nut Rigidity N/μm
								Dynamic Ca	Static Coa	
SWBS 1002 A	10	2	1.5875	10.3	3°32'	8.6	2.7□×1	2100	3800	196
SWBS 1002 B	10	2	1.5875	10.3	3°32'	8.6	3.7□×1	2700	5300	262
SWBS 1002.5 A	10	2.5	1.5875	10.3	4°25'	8.6	2.7□×1	2100	3800	196
SWBS 1002.5 B	10	2.5	1.5875	10.3	4°25'	8.6	3.7□×1	2700	5300	262
SWBS 1003 A	10	3	2	10.3	5°18'	8.2	2.7□×1	3000	5200	202
SWBS 1003 B	10	3	2	10.3	5°18'	8.2	3.7□×1	3900	7200	275
SWBS 1004 A	10	4	2	10.3	7°03'	8.2	2.7□×1	3000	5200	203
SWBS 1202 B	12	2	1.5875	12.3	2°58'	10.6	3.7□×1	3000	6400	307
SWBS 1202.5 B	12	2.5	1.5875	12.3	3°42'	10.6	3.7□×1	3000	6400	306
SWBS 1203 B	12	3	2	12.3	4°26'	10.2	3.7□×1	4300	8700	318
SWBS 1204 B	12	4	2.381	12.3	5°55'	9.8	3.7□×1	5400	10200	324

Ball Nut Model number	Nut dimension							
	D	L	L ₁	T	W	H	S	S ₁
SWBS 1002 A	23	37	17.5	2	5	3	12	2.5
SWBS 1002 B	23	42	20	2	5	3	16	2
SWBS 1002.5 A	24	41.5	19.5	2.5	5	3	12	3.5
SWBS 1002.5 B	24	47	22.5	2	5	3	16	3
SWBS 1003 A	24	46	22	2	5	3	16	3
SWBS 1003 B	24	53	25.5	2	5	3	20	3
SWBS 1004 A	24	54	26	2	5	3	20	3
SWBS 1202 B	25	44	20.5	3	5	3	16	2
SWBS 1202.5 B	26	47	22	3	5	3	16	3
SWBS 1203 B	28	56	26.5	3	5	3	20	3
SWBS 1204 B	28	67	32	3	5	3	25	3

- Note 1) The diameter of one of the Screw Shaft ends must be less than the Screw Shaft Root diameter, otherwise Ball Nut cannot be installed.
- Note 2) Ball Nut dimension is without seal at both ends.
If the seals are required, Ball Nut dimension should be changed, in that case, please ask ABSSAC.
Some type of Ball Nuts cannot equip with seals, please ask ABSSAC representative.
- Note 3) Rigidity
The Rigidity values shown in the table are theoretical values calculated from the amount of Elastic Displacement under the Preload equivalent to 10% of the Basic Dynamic Load Rating Ca.
- Note 4) All models are Right-hand screw. If Left-hand screw is required, please ask ABSSAC representative.

Precision Ball Screws

Sleeve type Double Nut

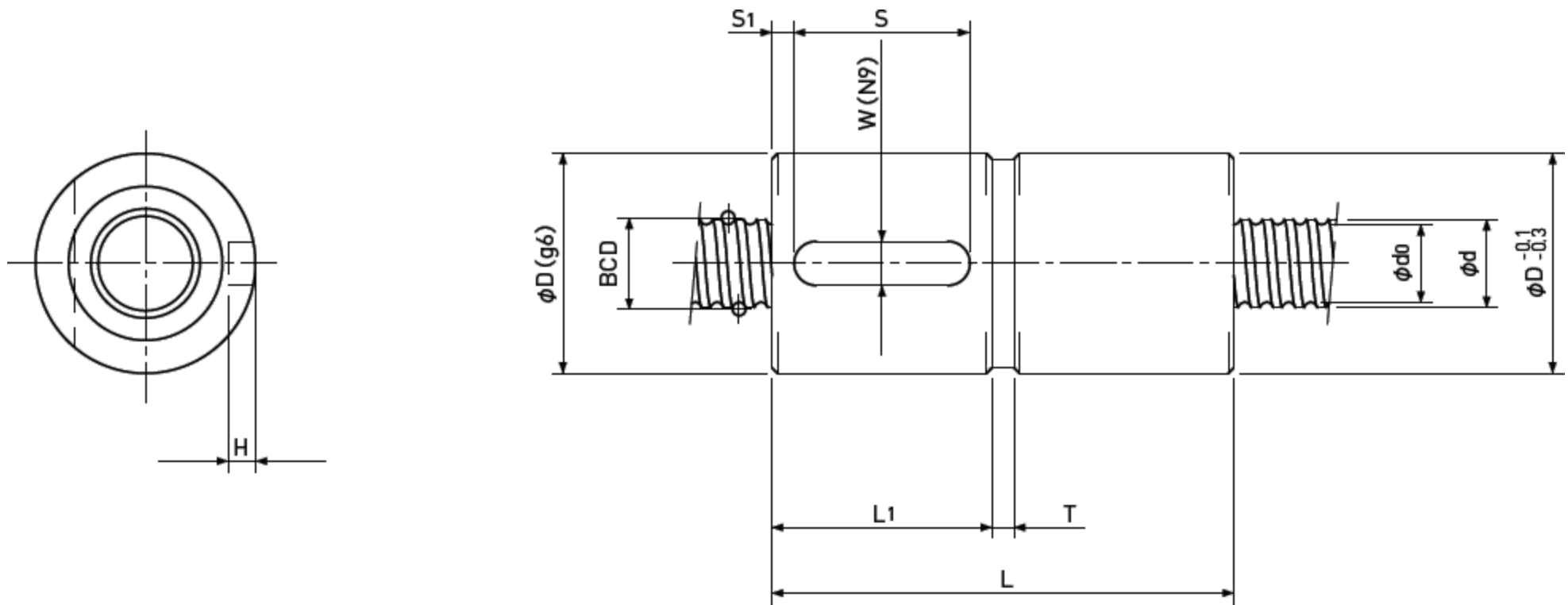

Unit : mm

Ball Nut Model number	Shaft nominal dia. d	Lead	Ball size	BCD	Lead angle	Root dia. d ₀	Number of Circuit	Basic Load Rating N		Nut Rigidity N/μm
								Dynamic Ca	Static Coa	
SWBS 1402 B	14	2	1.5875	14.3	2°33'	12.6	3.7□×1	3200	7500	345
SWBS 1402.5 B	14	2.5	1.5875	14.3	3°11'	12.6	3.7□×1	3200	7500	345
SWBS 1403 B	14	3	2	14.3	3°49'	12.2	3.7□×1	4600	10100	361
SWBS 1404 B	14	4	2.381	14.3	5°05'	11.8	3.7□×1	5700	11600	366
SWBS 1405 B	14	5	2.381	14.3	6°21'	11.8	3.7□×1	5700	11600	365
SWBS 1602 B	16	2	1.5875	16.3	2°14'	14.6	3.7□×1	3400	8600	386
SWBS 1602.5 B	16	2.5	1.5875	16.3	2°48'	14.6	3.7□×1	3400	8600	385
SWBS 1603 B	16	3	2	16.3	3°21'	14.2	3.7□×1	4900	11600	401
SWBS 1604 B	16	4	2.381	16.3	4°28'	13.8	3.7□×1	6200	13600	409
SWBS 1605 B	16	5	3.175	16.5	5°31'	13.2	3.7□×1	9100	18200	425

Ball Nut Model number	Nut dimension							
	D	L	L ₁	T	W	H	S	S ₁
SWBS 1402 B	26	44	20.5	3	5	3	16	2
SWBS 1402.5 B	28	47	22	3	5	3	16	3
SWBS 1403 B	30	56	26.5	3	5	3	20	3
SWBS 1404 B	30	67	32	3	5	3	25	3
SWBS 1405 B	30	78	37.5	3	5	3	28	5
SWBS 1602 B	28	44	20.5	3	5	3	16	2
SWBS 1602.5 B	28	47	22	3	5	3	16	3
SWBS 1603 B	32	56	26.5	3	5	3	20	3
SWBS 1604 B	34	68	32	4	5	3	25	3.5
SWBS 1605 B	38	83	39.5	4	5	3	28	5

- Note 1) The diameter of one of the Screw Shaft ends must be less than the Screw Shaft Root diameter, otherwise Ball Nut cannot be installed.
- Note 2) Ball Nut dimension is without seal at both ends.
If the seals are required, Ball Nut dimension should be changed, in that case, please ask ABSSAC.
Some type of Ball Nuts cannot equip with seals, please ask ABSSAC representative.
- Note 3) Rigidity
The Rigidity values shown in the table are theoretical values calculated from the amount of Elastic Displacement under the Preload equivalent to 10% of the Basic Dynamic Load Rating Ca.
- Note 4) All models are Right-hand screw. If Left-hand screw is required, please ask ABSSAC representative.