

Industrial Clutches

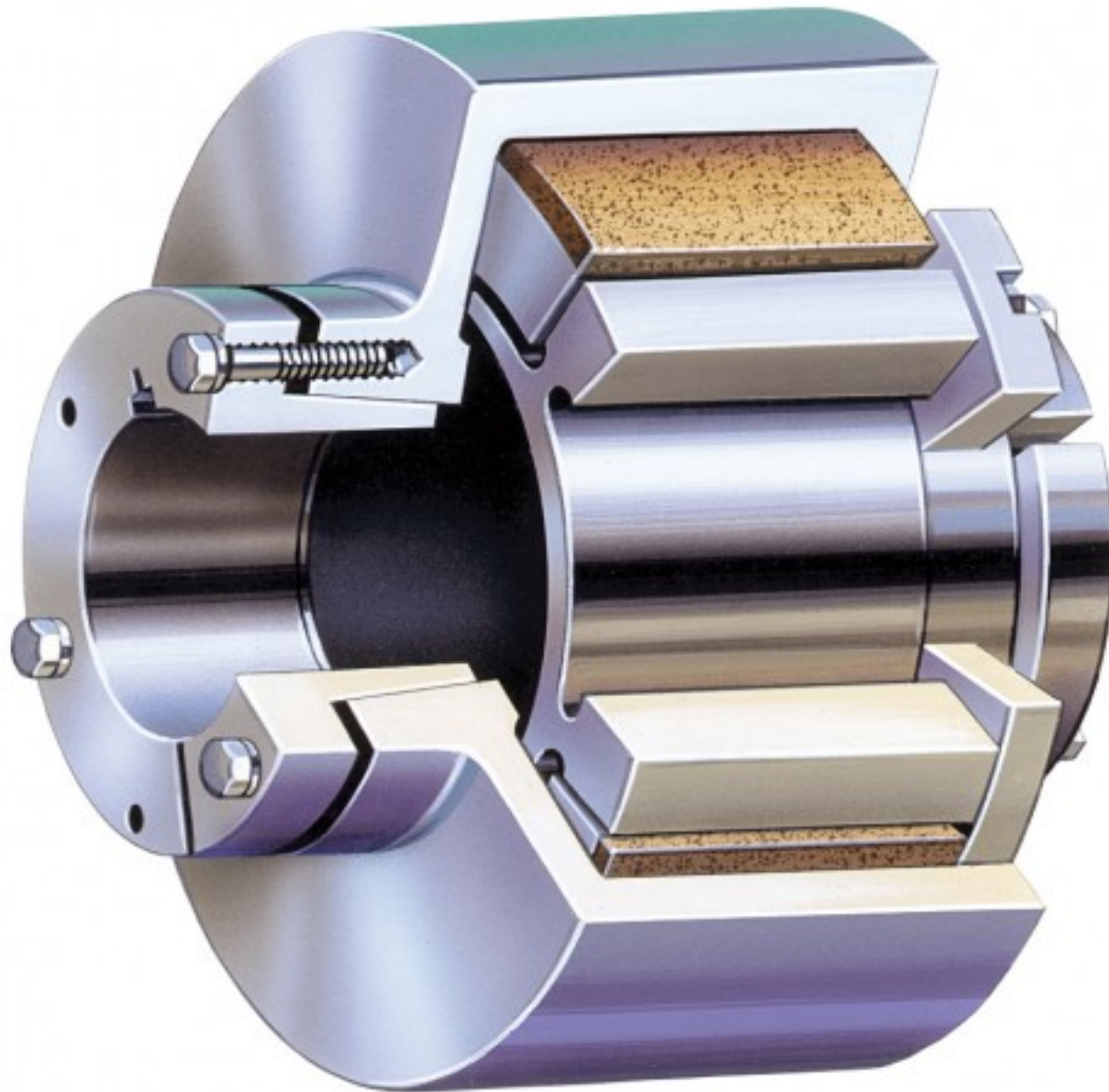

- TB Woods Clutches

Call: 01386 421 005

Email: sales@abssac.co.uk

Web: www.abssac.co.uk

ABSSAC
PRECISION MOTION SINCE 1982



CLUTCH PRODUCTS

Section G1

NLS® - Centrifugal Clutch

(No Load Start)

- cushion for high inertia starting loads
- dampens shock starts
- systems overload protection



Section G2

Roto-Cam® - Mechanical Clutch

- simple design
- smooth cam actuated engagements
- sealed for dirty or dusty applications
- no lubrication



Section G3

Disc-O-Torque® - Hydraulic Clutch

- minimum size | maximum torque
- lubricated and sealed bearing types
- air or oil activation
- long life



W NLS® CENTRIFUGAL CLUTCH

TB Wood's

The NLS centrifugal clutch is a rugged time-proven unit which provides equipment protection and system overload protection. This is done by allowing the motor or other driving source to accelerate to operating speed without load and to slip automatically when overloaded. This clutch is available in a free (type A) and delayed engagement (type AD) model, also in various sizes to handle different horsepower capacities.

TYPE A

Free Engagement

The shoes are a free floating part of the driving unit to which the power is applied. As the driver picks up speed, the shoes are forced outward by centrifugal force to make contact with the inside surface of the driven half. The shoes will make smooth contact and slip until the load reaches full speed. Both members then rotate as a unit with no slippage or power loss. Larger units have both inner and outer shoes.

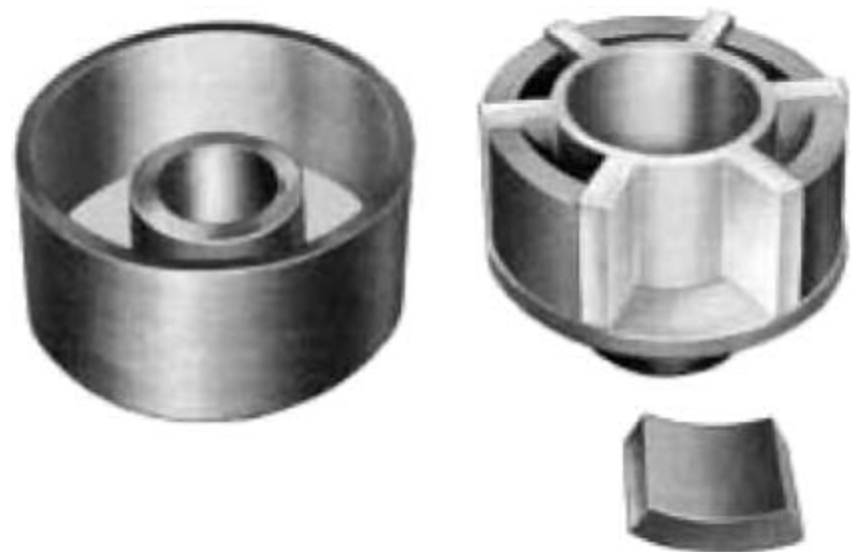

TYPE AD

Delayed Engagement

Operating under the same principle as the type A unit, the type AD uses springs to hold the shoes out of engagement until the driver reaches a predetermined rpm. At this point centrifugal force, acting on the shoes, overcomes the spring force, allowing smooth engagement of the power source with the load. Because the shoes are out of engagement until the driver is above the predetermined speed, this unit is ideal for dual or stand-by drives as well as idling or warming-up engines.





NLS® SELECTION PROCEDURE

Easy Step by Step Selection Method

Step # 1: Determine HP and minimum driving RPM (also idle RPM if delayed engagement type is required).

Step # 2: Using the service factor chart determine the proper service factor based on the prime mover and driven equipment.

	DRIVEN EQUIPMENT LOAD CLASSIFICATIONS			
	LIGHT STEADY LOADS Starting torque is equal to or slightly greater than running torque.	MODERATE LOADS High starting torque or above average running torque.	MEDIUM LOADS Starting torque is approximately double running torque.	HEAVY-DUTY LOADS High starting torque, shock loading, light torque reversals during drive.
PRIME MOVER	Centrifugal pumps, uniformly loaded conveyors, light-duty fans and blowers, liquid mixers and agitators, centrifugal compressors, lobe and vane type blowers, gear pumps, textile machinery, wood-working machinery.	Machine tools, hot oil pumps, heavy-duty centrifugal pumps, cooling towers, slurry agitators, boiler feed pumps, hoists, conveyors.	Dredge pumps, dynamometer drives, light-duty hammermills, lineshafts, paper converting machinery, rotary kins, rotary or screw-type pumps for high viscosity fluids, paper mill cranes.	Mine ventilating fans, reciprocating pumps or compressors, paper making machinery, heavy-duty hammermills, ore crushers, pulverizing mills.
Steam, gas or air turbine	1.00	1.25	1.50	1.75
AC electric motor	1.25	1.50	1.50	1.75
DC electric motor or DOL start AC electric motor, hydraulic motors	1.25	1.50	1.75	2.00
Gasoline, natural gas, propane or other spark ignition engine	1.75	1.75	2.00	CONSULT ENGINEERING
Diesel*	2.00	2.50	2.75	CONSULT ENGINEERING

* Consult Wood's applications engineering on all engine drives

Dual drive applications are to be treated as two single drives for service factor purposes.

For conveyor applications consult Wood's applications engineering.

For any application with extremes in inertia, starting torque, or questionable equipment, consult Wood's application engineering.



NLS® SELECTION PROCEDURE (continued)

Step # 3: Calculate the Design HP (HP x service factor). Using the Design HP and the driving RPM select the type and size clutch from the following charts.

TYPE A Free Engagement Horsepower Tables

In Wood's NLS free engagement clutch the shoes are a free-moving part of the driving half of the twopiece unit to which the power is applied. As the driving half picks up speed the shoes are forced outward by centrifugal force into contact with the inside surface of the driven half which is attached to the load or driven machine. As the shoes make smooth contact, they slip momentarily, or until friction causes the driven half to rotate. When the driven equipment reaches full speed, complete engagement of the shoes with the driven half has taken place, and both members rotate as a unit with **no slippage, or power loss**.

Description	Bushing	Product Number	Minimum Dynamic HP							Shoe Replacement			
			Minimum Driving RPM							Outer		Inner	
			400	500	600	720	870	1160	1750	Product No.	Qty.	Product No.	Qty.
4A-1	SH	N004-1	0.02	0.04	0.07	0.11	0.20	0.50	1.60	N004-408	2	NONE	
4A-2	SH	N004-2	0.04	0.07	0.13	0.23	0.40	0.90	3.30	N004-408	4	NONE	
4A-3	SH	N004-3	0.05	0.09	0.15	0.27	0.50	1.10	3.90	N004-412	4	NONE	
6A-1	SDS	N006-1	0.09	0.20	0.30	0.50	1.00	2.40	8.00	N006-613	2	NONE	
6A-2	SDS	N006-2	0.15	0.30	0.50	0.90	1.60	3.80	13.00	N006-613	3	NONE	
6A-3	SDS	N006-3	0.20	0.40	0.70	1.20	2.10	5.00	17.00	N006-613	4	NONE	
6A-4	SDS	N006-4	0.29	0.60	1.00	1.80	3.20	7.50	26.00	N006-613	6	NONE	
7A-1	SK	N007-1	0.38	0.75	1.30	2.20	3.90	9.40	32.00	N007-726	3	NONE	
7A-2	SK	N007-2	0.51	1.00	1.70	3.00	5.20	12.00	43.00	N007-726	4	NONE	
7A-3	SK	N007-3	0.77	1.50	2.60	4.50	7.90	19.00	64.00	N007-726	6	NONE	
8A-1	SF	N008-1	0.90	1.80	3.20	5.60	9.80	23.00	80.00	N008-834	4	NONE	
8A-2	SF	N008-2	1.00	2.00	3.60	6.00	11.00	26.00	88.00	N008-842	4	NONE	
8A-3	SF	N008-3	1.30	2.70	4.90	8.20	14.00	35.00	120.00	N008-834	6	NONE	
8A-4	SF	N008-4	1.50	3.00	5.40	9.10	16.00	38.00	132.00	N008-842	6	NONE	
10A-1	E	N010-1	1.50	3.00	5.50	9.00	16.00	38.00	132.00	N010-1033	4	N010-1026-I	4
10A-2	E	N010-2	1.50	3.50	6.00	10.00	18.00	43.00	149.00	N010-1042	4	N010-1026-I	4
10A-3	E	N010-3	2.00	4.50	7.50	13.00	24.00	56.00	192.00	N010-1033	6	N010-1026-I	6
10A-4	E	N010-4	2.50	5.00	9.00	15.00	28.00	65.00	224.00	N010-1042	6	N010-1026-I	6
12A-1	F	N012-1	3.00	6.50	12.00	19.00	35.00	82.00	285.00	N012-1275	3	N012-1256-I	3
12A-2	F	N012-2	4.00	8.50	16.00	26.00	47.00	110.00	380.00	N012-1275	4	N012-1256-I	3
12A-3	F	N012-3	6.00	12.00	21.00	36.00	65.00	154.00	533.00	N012-1260	6	N012-1256-I	6
12A-4	F	N012-4	6.50	13.00	23.00	39.00	70.00	165.00	570.00	N012-1275	6	N012-1256-I	6
14A-1	F	N014-1	8.50	17.00	31.00	51.00	92.00	217.00	749.00	N014-1453	6	N014-1468-I	3
14A-2	F	N014-2	10.00	20.00	36.00	60.00	108.00	255.00	879.00	N014-1470	6	N014-1468-I	4
14A-3	F	N014-3	13.00	27.00	48.00	81.00	144.00	340.00	1170.00	N014-1470	8	N014-1468-I	6
16A-1	J	N016-1	13.00	26.00	47.00	79.00	141.00	333.00	1150.00	N016-16110	4	N016-16100-I	3
16A-2	J	N016-2	14.00	28.00	50.00	84.00	150.00	354.00	1220.00	N016-1685	6	N016-16100-I	4
16A-3	J	N016-3	20.00	39.00	70.00	118.00	212.00	499.00	1720.00	N016-16110	6	N016-16100-I	4
16A-4	J	N016-4	26.00	53.00	93.00	158.00	282.00	666.00	2290.00	N016-16110	8	N016-16100-I	6
19A-1	BTS	N019-1	43.00	87.00	154.00	260.00	461.00	1090.00	...	N019-19150	6	N019-19100-I	6
19A-2	BTS	N019-2	57.00	115.00	204.00	346.00	614.00	1450.00	...	N019-19150	8	N019-19100-I	8
24A-1	BTS	N024-1	77.00	156.00	276.00	468.00	828.00	1967.00	...	N024-24140	8	N024-24180-I	4
24A-2	BTS	N024-2	114.00	221.00	391.00	663.00	1170.00	2785.00	...	N024-24200	8	N024-24180-I	6
24A-3	BTS	N024-3	164.00	332.00	587.00	995.00	1760.00	4180.00	...	N024-24200	12	N024-24180-I	8
24A-4	BTS	N024-4	219.00	443.00	783.00	1327.00	2345.00	5570.00	...	N024-24200	16	N024-24220-I	8
25A-1	BTS	N025-1	246.00	498.00	881.00	1490.00	2640.00	6270.00	...	N024-24200	18	N024-24180-I	8
25A-2	BTS	N025-2	287.00	581.00	1030.00	1740.00	3080.00	7310.00	...	N024-24200	21	N024-24220-I	8
25A-3	BTS	N025-3	342.00	669.00	1160.00	2000.00	3530.00	8360.00	...	N024-24200	24	N024-24180-I	8

Horsepower tables are based on ideal test conditions. As with all friction clutches, the actual horsepower will vary with application conditions.

When using a model with inner shoes:

A) Horsepower ratings prior to shoe lock-up (dynamic horsepower ratings) do not include inner shoe.

B) Horsepower rating after complete shoe lock-up with inner shoe (static horsepower ratings) are approximately double the dynamic rating.

For high speed applications and models above 10", consult TB Wood's application engineering.

W[®] NLS[®] SELECTION PROCEDURE (continued)

TB Wood's

TYPE AD

Delayed Engagement Horsepower Tables

In Wood's NLS delayed engagement clutch, shoe engagement is controlled by springs. The springs are fastened to the clutch shoes and inserted in slots in the driving half. Spring action holds the shoes out of engagement with the driven half until the driving half reaches a pre-determined RPM. Above this RPM, centrifugal force acting on the shoes overcomes the spring force allowing smooth engagement of the power source with the driven equipment. Since the shoes do not contact the driven half unless the driving half is started and accelerated, the delayed engagement type A D is ideal for dual or standby drives. The cushioned contact also means no sudden load imposed on motor, electrical, clutch or driven equipment.

Description	Bushing	Product Number	Minimum Dynamic HP				Max Idle RPM	Shoe Replacement	
			Minimum Driving RPM					Product No.	Qty.
			870/300*	1160/700*	1750/1000*	2500/1500*			
4AD-1	SH	N104-1	0.18	0.31	1.10	3.20	300-1500	N104-9001	2
4AD-2	SH	N104-2	0.37	0.63	2.30	6.40	300-1500	N104-9001	4
6AD-1	SDS	N106-1	0.80	1.40	5.00	14.60	300-1500	N106-9001	2
6AD-2	SDS	N106-2	1.20	2.10	8.00	21.90	300-1500	N106-9001	3
6AD-3	SDS	N106-3	1.70	2.80	10.50	29.20	300-1500	N106-9001	4
6AD-4	SDS	N106-4	2.50	4.30	15.50	43.80	300-1500	N106-9001	6
7AD-1	SK	N107-1	3.00	5.00	18.50	50.00	300-1500	N107-9001	3
7AD-2	SK	N107-2	4.00	6.80	24.50	67.00	300-1500	N107-9001	4
7AD-3	SK	N107-3	6.00	10.90	37.00	100.00	300-1500	N107-9001	6
8AD-1	SF	N108-1	7.50	13.00	47.00	136.00	300-1500	N108-9001	4
8AD-2	SF	N108-2	11.50	19.50	71.00	204.00	300-1500	N108-9001	6
10AD-1	SF	N110-1	17.00	30.00	109.00	-	300-1000	N110-9001	4
10AD-2	SF	N110-2	26.00	45.00	164.00	-	300-1000	N110-9001	6
12AD-1	F	N112-1	27.00	47.00	173.00	-	300-1000	N112-9001	2
12AD-2	F	N112-2	41.00	71.00	259.00	-	300-1000	N112-9001	3
12AD-3	F	N112-3	55.00	95.00	346.00	-	300-1000	N112-9001	4
12AD-4	F	N112-4	83.00	142.00	519.00	-	300-1000	N112-9001	6
14AD-1	F	N114-1	73.00	125.00	-	-	200-700	N114-9001	4
14AD-2	F	N114-2	110.00	188.00	-	-	200-700	N114-9001	6
14AD-3	F	N114-3	147.00	251.00	-	-	200-700	N114-9001	8
16AD-1	J	N116-1	100.00	172.00	-	-	200-700	N116-9001	2
16AD-2	J	N116-2	201.00	344.00	-	-	200-700	N116-9001	4
16AD-3	J	N116-3	302.00	516.00	-	-	200-700	N116-9001	6
16AD-4	J	N116-4	402.00	689.00	-	-	200-700	N116-9001	8
19AD-1	BTS	N119-1	521.00	-	-	-	200-500	N119-9001	6
19AD-2	BTS	N119-2	695.00	-	-	-	200-500	N119-9001	8
24AD-1	BTS	N124-1	701.00	-	-	-	50-300	N124-9001	4
24AD-2	BTS	N124-2	1402.00	-	-	-	50-300	N124-9001	8
24AD-3	BTS	N124-3	2103.00	-	-	-	50-300	N124-9001	12
24AD-4	BTS	N124-4	2805.00	-	-	-	50-300	N124-9001	16

* Horsepower ratings listed are based on idle speed as indicated.
For high speed applications, models above 10", or special idle speeds, consult TB Wood's application engineering.
Horsepower ratings listed are based on ideal test conditions. As with all friction clutches, the actual horsepower will vary with application conditions.

Step # 4: Check high speed applications for dynamic balancing and steel band requirements.

Clutch Size	RPM	
	Dynamic Balance Between	Steel Band on Required Output member above
4	4700-11500	5700
6	3200-7600	3900
7	2700-6600	3300
8	2400-5700	2900
10	1900-4600	2300
12	1225-3800	1900
14	1400-3300	1600
16	1200-2900	1400
19	1000-1750	1200
24	900-1600	1000
25	500-1600	1000

WMI[®] NLS[®] SELECTION PROCEDURE (continued)
TB Wood's

Step # 5: Check bore size and available space envelope.

TYPE A
Free Engagement

Dimensions in Inches

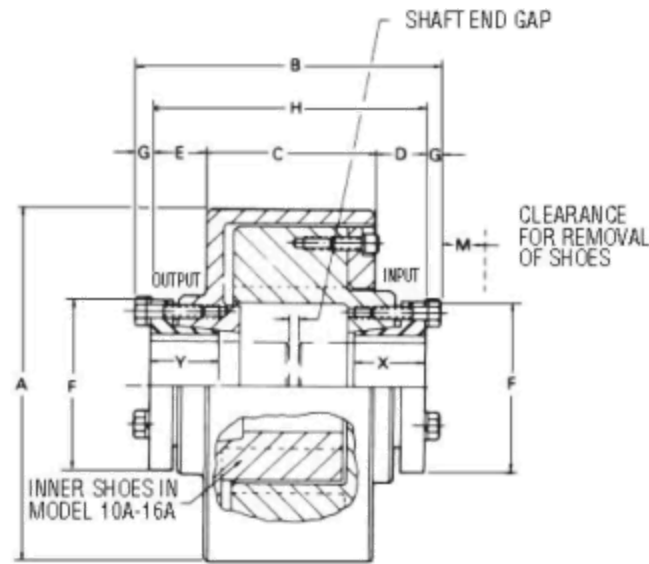

MODELS 4A THRU 16A

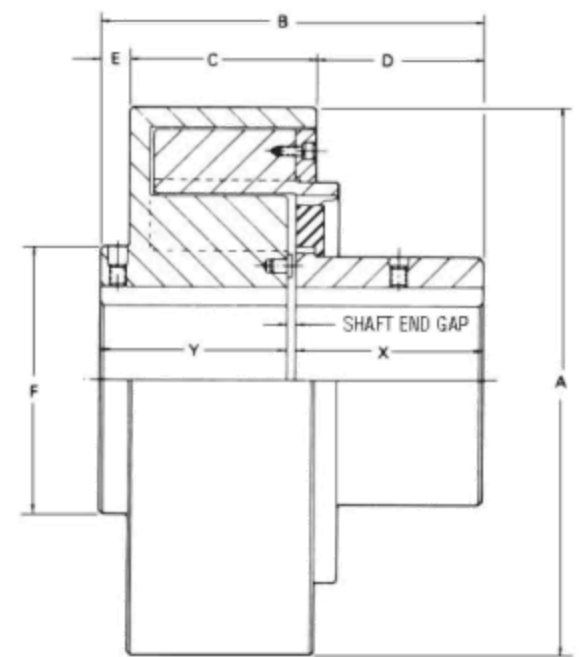

MODELS 19A & 24A

Clutch Size	Sure-Grip Bushing	A	A with Steel Band	B	C	D	E	F	G	H	X	Y	Shaft End Cap		M	B+M	Approx. Wt. Lbs.
													Min	Max			
4A	SH	4-7/16	-	4-13/16	2-1/4	1-1/8	1	2-3/4	1/4	4-3/8	1-1/16	1-1/16	1/16	2	0	4-13/16	8
6A	SDS	6-1/2	7-7/16	5-17/32	3-1/16	15/16	1-1/32	3-1/8	1/4	5-1/32	1-5/16	1-5/16	1/8	2-13/32	13/16	6-11/32	25
7A	SK	7-5/8	8-7/16	7-5/16	3-5/8	1-1/2	1-9/16	3-7/8	5/16	6-11/16	1-15/16	1-15/16	1/8	2-13/16	11/16	8	40
8A	SF	8-3/4	9-7/16	8	4-1/4	1-9/32	1-25/32	4-5/8	11/32	7-5/16	2-1/4	2-1/4	1/8	2-13/16	1-7/8	9-7/8	55
10A	E	10-3/4	11-3/4	10-1/2	4-1/8	3-1/8	2-1/4	6	1/2	9-1/2	3	3	1/8	3-1/2	0	10-1/2	105
12A	F	13	14	11-3/8	5-1/2	3-7/16	1-5/15	6-5/8	9/16	10-1/4	3-15/16	3-15/16	1/8	2-3/8	0	11-3/8	225
14A	F	15	16	11-3/8	5-1/2	3-7/16	1-5/16	6-5/8	9/16	10-1/4	3-15/16	3-15/16	1/8	2-3/8	0	11-3/8	250
16A	J	17-1/4	18-1/4	13-5/8	6-5/8	4-3/16	1-9/16	7-1/4	5/8	12-3/8	4-7/8	4-7/8	1/8	2-5/8	0	13-5/8	400
19A	BTS	20-1/2	21-1/2	14-3/16	6-7/8	6-1/4	1-1/16	10	-	-	7	7	1/8	3/16	0	14-3/16	600
24A	BTS	25-1/2	26-1/2	19-1/16	9-7/8	8	1-1/16	12-1/2	-	-	8-3/4	10	1/8	3/16	0	19-1/16	1225
25A	BTS	-	26-1/2	24-3/16	13-7/8	9-1/4	1-1/16	12-1/2	-	-	10	10	1/8	4-5/64	0	24-3/16	1400

TYPE AD
Delayed Engagement

Dimensions in Inches

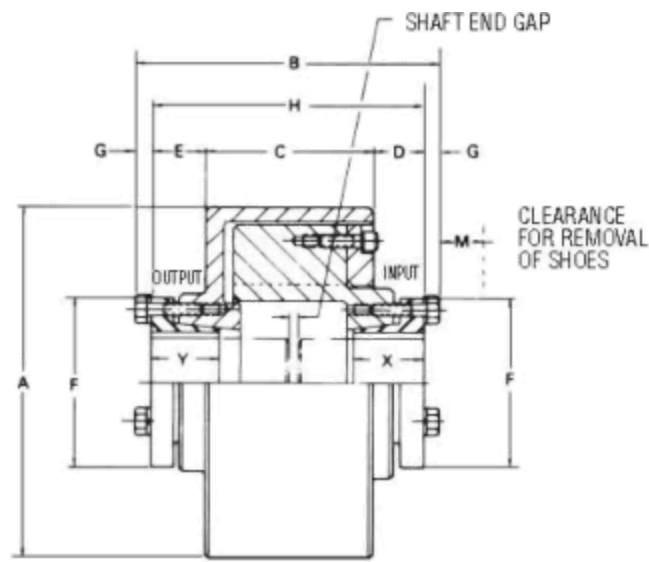

MODELS 4AD THRU 16AD

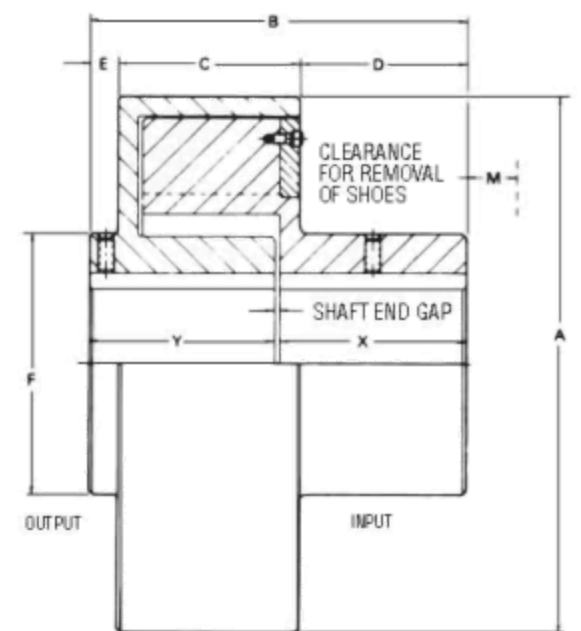

MODELS 19AD & 24AD

Clutch Size	Sure-Grip Bushing	A	A with Steel Band	B	C	D	E	F	G	H	X	Y	Shaft End Cap		M	B+M	Approx. Wt. Lbs.
													Min	Max			
4AD	SH	4-7/16	-	4-13/16	2-1/4	1-1/8	1	2-3/4	1/4	4-3/8	1-1/16	1-1/16	1/16	2	0	4-13/16	8
6AD	SDS	6-1/2	7-7/16	5-17/32	3-1/16	15/16	1-1/32	3-1/8	1/4	5-1/32	1-5/16	1-5/16	1/8	2-13/32	13/16	6-11/32	25
7AD	SK	7-5/8	8-7/16	7-5/16	3-5/8	1-1/2	1-9/16	3-7/8	5/16	6-11/16	1-15/16	1-15/16	1/8	2-13/16	11/16	8	40
8AD	SF	8-3/4	9-7/16	8	4-1/4	1-9/32	1-25/32	4-5/8	11/32	7-5/16	2-1/4	2-1/4	1/8	2-13/16	1-3/8	9-3/8	55
10AD	SF	10-3/4	11-3/4	8-9/16	4-1/8	2	1-3/4	5-1/8	11/32	7-7/8	2-1/4	2-1/4	1/8	3-1/2	11/16	9-1/4	105
12AD	F	13	14	11-3/8	5-1/2	3-7/16	1-5/16	6-5/8	9/16	10-1/4	3-15/16	3-15/16	1/8	2-3/8	5/8	12	215
14AD	F	15	16	11-3/8	5-1/2	2-1/8	1-5/16	6-5/8	9/16	10-1/4	3-15/16	3-15/16	1/8	2-3/8	5/8	12	240
16AD	J	17-1/4	18-1/4	13-5/8	6-5/8	4-3/16	1-9/16	7-1/4	5/8	12-3/8	4-7/8	4-7/8	1/8	2-5/8	5/8	14-1/4	385
19AD	BTS	20-1/2	21-1/2	14-3/16	6-7/8	6-1/4	1-1/16	10	-	-	7	7	1/8	3/16	0	14-3/16	575
24AD	BTS	25-1/2	26-1/2	18-15/16	9-7/8	8	1-1/16	12-1/2	-	-	8-3/4	8-3/4	1/8	1-7/16	0	18-15/16	1175



NLS® SELECTION PROCEDURE (continued)

Bore and keyseat information

Sure Grip Bushing	Bores	Keyseat	Sure Grip Bushing	Bores	Keyseat	Standard Keyseat Dimensions		
						Shaft Dia.	Width	Depth
SH	1/2 - 1-3/8	Standard	E	7/8 - 2-7/8	Standard	1/2 - 9/16	1/8	1/16
	1-7/16 - 1-5/8	3/8 x 1/16		2-15/16 - 3-1/4	3/4 x 1/8	5/8 - 7/8	3/16	3/32
	1-11/16	No K.S.		3-5/16 - 3-1/2	7/8 x 1/16	15/16 - 1-1/4	1/4	1/8
SDS	1/2 - 1-11/16	Standard	F	1 - 3-1/4	Standard	1-5/16 - 1-3/8	5/16	5/32
	1-3/4	3/8 x 1/8		3-5/16 - 3-3/4	7/8 x 3/16	1-7/16 - 1-3/4	3/8	3/16
	1-13/16	1/2 x 1/8		3-13/16 - 3-15/16	1 x 1/8	1-13/16 - 2-1/4	1/2	1/4
	1-7/8 - 1-15/16	1/2 x 1/16		4	No K.S.	2-5/16 - 2-3/4	5/8	5/16
	2	No K.S.	J	1-7/16 - 3-13/16	Standard	2-13/16 - 3-1/4	3/4	3/8
		3-7/8 - 3-15/16		1 x 3/8	3-15/16 - 3-3/4	7/8	7/16	
SK	1/2 - 2-1/8	Standard	BTS NLS Models			3-13/16 - 4-1/2	1	1/2
	2-3/16 - 2-1/4	1/2 x 1/8	Model	Bores	Keyseat	4-9/16 - 5-1/2	1-1/4	5/8
	2-5/16 - 2-1/2	5/8 x 1/16	19A & 19AD	3 - 5-5/8	Standard	5-9/16 - 6-1/2	1-1/2	3/4
	2-9/16 - 2-5/8	No K.S.	24A, 25A & 24AD	5-11/16 - 6-5/8	Shallow	6-9/16 - 7-1/2	1-3/4	3/4
		3-1/4 - 7		Standard	7-9/16 - 9	2	3/4	
SF	1/2 - 2-1/4	Standard		7-1/16 - 8-3/8	Shallow			
	2-5/16 - 2-1/2	5/8 x 3/16						
	2-9/16 - 2-3/4	5/8 x 1/16						
	2-13/16 - 2-15/16	No K.S.						

NOTE: When installing Sure-Grip bushings follow wrench torque supplied in NLS instructions.

Step # 6: Check clutch capacity for high inertia starts. If inertia is not known or clutch speed is not listed, see step # 7.

Maximum WR ² (lbs. ft. ²) that may be started at standard motor speeds.							
Clutch	870 RPM	1170 RPM	1750 RPM	Clutch	870 RPM	1170 RPM	1750 RPM
4	500	290	130	14	8000	4700	2100
6	1400	800	350	16	15000	8000	3700
7	2000	1100	510	19	22000	13000	5600
8	3000	1700	790	24	38000	20000	-
10	3800	2100	880	25	47600	26400	-
12	7000	4000	1800				

Step # 7: If inertia is not known or clutch speed is not listed on WR2 chart.

ACCELERATION TABLE

Clutch Model No.	Energy Capacity Horsepower-Seconds
4A, 4AD	245
6A, 6AD	680
7A, 7AD	980
8A, 8AD	1,400
10A, 10AD	1,650
12A, 12AD	3,400
14A, 14AD	4,000
16A, 16AD	7,200
19A, 19AD	11,000
24A, 24AD	17,000
25A	25,000
30A	38,000

Maximum allowable acceleration time in seconds can be calculated by dividing the energy capacity in horsepower-seconds by the clutch design horsepower.

If actual acceleration time exceeds the maximum allowable time, a larger clutch should be selected or if the start-up frequency is more than 1 every half-hour.

Example: A 12A-3 is rated at 533 hp @ 1750 with an energy capacity of 3400 Horsepower-seconds

$$\frac{3400 \text{ Horsepower-seconds}}{533 \text{ Horsepower}} = 6.4 \text{ seconds maximum allowable acceleration time without a Steel Band}$$

By adding a Steel Band the acceleration time is increased by 35%

$$6.4 \times 1.35 = 8.6 \text{ seconds with a Steel Band}$$



NLS® SELECTION PROCEDURE (continued)

Step # 8: Specify the clutch selected.

Nxxx-x- x-x-x

Basic clutch *Product Number*
(Chart Step # 3)

Modification Codes
(Listed in alphabetical order)

Codes

B - Dynamic Balance

L - Limited End Float

S - Steel Band on Output

Sure-Grip bushings are sold separately.

Ordering examples:

N016-2	16A-2 clutch (no modifications)
N016-2-B	16A-2 clutch with dynamic balancing
N016-2-S	16A-2 clutch with steel ring
N016-2-B-S	16A-2 clutch with dynamic balancing and steel ring
N016-B-L-S	16A-2 clutch with dynamic balancing, limited end float, and steel ring
J3316	J Sure-Grip bushing with a 3-3/16 bore

Note: All NLS clutches use non-asbestos shoe linings.