

Jaw Couplings SPRFLEX



High flexibility



High damping



RoHS

Max. nominal torque [N·m]	50
Pilot bore/added work ranges [mm]	φ 4 ~ 48
Operating temperature [°C]	- 20 ~ 80
Backlash	Yes
Driver	Induction motor
Application	Pumps, fans, textile machinery

Jaw Couplings that Use Rubber as Buffer Material

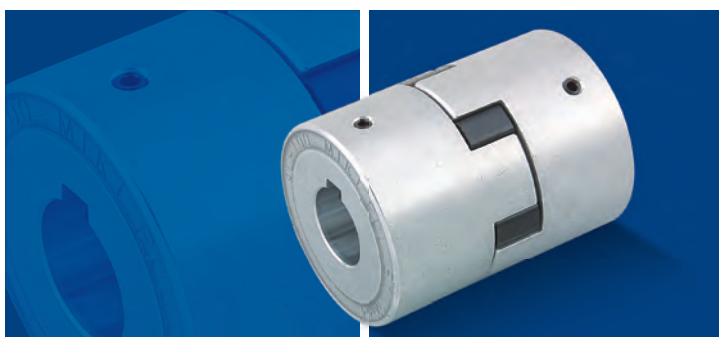

These jaw couplings have simpler designs that sandwich a buffer material (spider) between two hubs. The hub is lightweight, being made of aluminum alloy. Input and output can be coupled or separated easily by simply moving the coupling in the axial.

Structure and Materials

■ Pilot bore

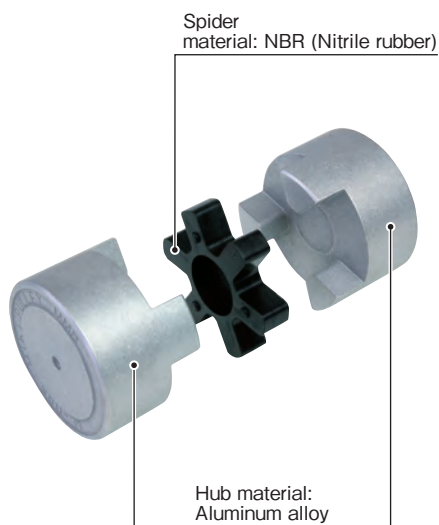

■ Key/set screw types

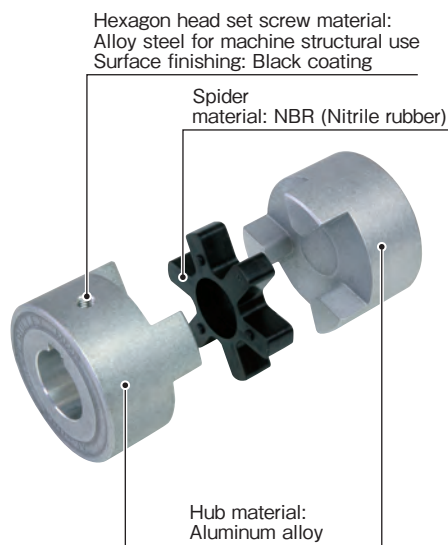

■ Spider (rubber buffer)



AL Models

Specifications

Model	Torque		Misalignment			Max. rotation speed [min ⁻¹]	Moment of inertia [kg·m ²]	Mass [kg]
	Nominal [N·m]	Max. [N·m]	Parallel [mm]	Angular [°]	Axial [mm]			
AL-035	0.5	1.5	0.1	0.5	+ 0.3	18000	0.38×10^{-6}	0.01
AL-050	1.5	4.5	0.2	1.0	± 0.5	12000	5.10×10^{-6}	0.06
AL-070	3	9	0.2	1.0	± 0.5	9000	1.79×10^{-5}	0.12
AL-075	5	15	0.2	1.0	± 0.5	7000	5.36×10^{-5}	0.21
AL-090	8	24	0.3	1.0	± 0.5	6000	1.15×10^{-4}	0.31
AL-095	10	30	0.3	1.0	± 0.5	6000	1.40×10^{-4}	0.36
AL-100	25	75	0.3	1.0	± 0.7	5000	4.34×10^{-4}	0.78
AL-110	50	150	0.3	1.0	± 0.7	4000	1.43×10^{-3}	1.56

* Max. rotation speed does not take into account dynamic balance or mounting misalignment.
 * The moment of inertia and mass are measured for the pilot bore.

Dimensions (Couplings)

Unit [mm]

Model	d1 · d2			D	L	L1	L2
	Pilot bore	Min.	Max.				
AL-035	4	4	8	16.1	20.5	6.5	7.5 ^{*1}
AL-050	5	6	16	27	43.2	15.5	12.2
AL-070	5	6	20	35	49.2	18.5	12.2
AL-075	5	7	26	45	54.4	21.0	12.4
AL-090	5	9	28	54	55.0	21.0	13.0
AL-095	5	9	28	55	61.0	24.0	13.0
AL-100	5	11	36	66	88.0	35.0	18.0
AL-110	5	11	48	85	110.0	44.0	22.0

* "Pilot bore" refers to center processing. Minimums and maximums for d1 and d2 are values at the MIKI PULLEY standard hole-drilling standards.

* The value marked *1 leaves a 1 mm space for the thickness of the spider body.

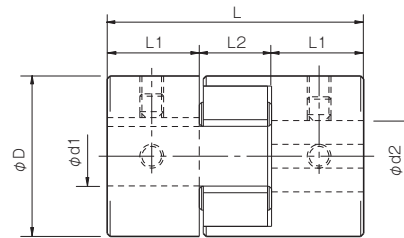

Dimensions (Spider)

Unit [mm]

Model	L2	R	K
L-035	6.5	—	—
L-050	12.2	—	—
L-070	12.2	—	—
L-075	12.4	20	6.0
L-090	13.0	22	6.3
L-095	13.0	22	6.3
L-100	18.0	26	6.0
L-110	22.0	30	6.0

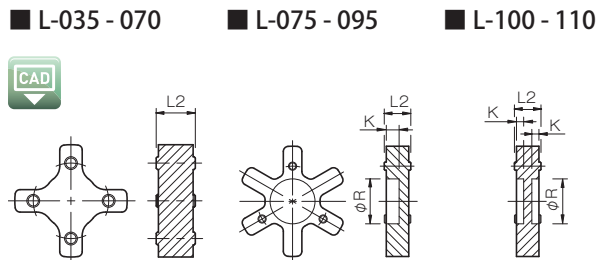

How to Place an Order

Pilot Bore

AL-050
 Size

Key/Set Screw Types

AL-050 12H-14N
 Size Bore diameter: d1 (Small diameter) · d2 (Large diameter)
 Bore specifications
 Blank: Compliant with the old JIS standards (class 2)
 H: Compliant with the new JIS standards
 N: Compliant with the new motor standards

Spiders

L-090
 Size

MODELS

AL

AL Models

Standard Hole-Drilling Standards

- Set screw and keyway positions are not on the same plane. Positioning precision for keyway milling is determined by sight, so contact Miki Pulley when the keyway requires a positioning precision for a particular hub.
- The set screws are included with the product.

■ AL-035 to 070

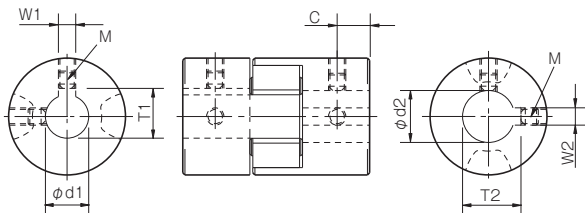

■ AL-075 to 110

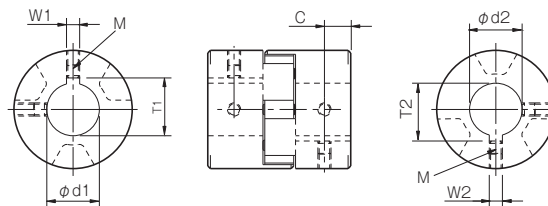

Unit [mm]

Models compliant with the old JIS standards (class 2)					Models compliant with the new JIS standards					Models compliant with the new motor standards				
Nominal bore diameter	Bore diameter [d1 · d2]	Keyway width [W1 · W2]	Keyway height [T1 · T2]	Set screw hole [M]	Nominal bore diameter	Bore diameter [d1 · d2]	Keyway width [W1 · W2]	Keyway height [T1 · T2]	Set screw hole [M]	Nominal bore diameter	Bore diameter [d1 · d2]	Keyway width [W1 · W2]	Keyway height [T1 · T2]	Set screw hole [M]
Tolerance	H7, H8	E9	+0.3 0	—	Tolerance	H7	H9	+0.3 0	—	Tolerance	G7, F7	H9	+0.3 0	—
6	6 ^{+0.018} ₀	—	—	2-M4	—	—	—	—	—	—	—	—	—	—
7	7 ^{+0.022} ₀	—	—	2-M4	—	—	—	—	—	—	—	—	—	—
8	8 ^{+0.022} ₀	—	—	2-M4	—	—	—	—	—	—	—	—	—	—
9	9 ^{+0.022} ₀	—	—	2-M4	—	—	—	—	—	—	—	—	—	—
10	10 ^{+0.022} ₀	—	—	2-M4	—	—	—	—	—	—	—	—	—	—
11	11 ^{+0.018} ₀	—	—	2-M4	—	—	—	—	—	—	—	—	—	—
12	12 ^{+0.018} ₀	4 ^{+0.050} _{+0.020}	13.5	2-M4	12H	12 ^{+0.018} ₀	4 ^{+0.030} ₀	13.8	2-M4	—	—	—	—	—
14	14 ^{+0.018} ₀	5 ^{+0.050} _{+0.020}	16.0	2-M4	14H	14 ^{+0.018} ₀	5 ^{+0.030} ₀	16.3	2-M4	14N	14 ^{+0.024} _{+0.006}	5 ^{+0.030} ₀	16.3	2-M4
15	15 ^{+0.018} ₀	5 ^{+0.050} _{+0.020}	17.0	2-M4	15H	15 ^{+0.018} ₀	5 ^{+0.030} ₀	17.3	2-M4	—	—	—	—	—
16	16 ^{+0.018} ₀	5 ^{+0.050} _{+0.020}	18.0	2-M4	16H	16 ^{+0.018} ₀	5 ^{+0.030} ₀	18.3	2-M4	—	—	—	—	—
17	17 ^{+0.018} ₀	5 ^{+0.050} _{+0.020}	19.0	2-M4	17H	17 ^{+0.018} ₀	5 ^{+0.030} ₀	19.3	2-M4	—	—	—	—	—
18	18 ^{+0.018} ₀	5 ^{+0.050} _{+0.020}	20.0	2-M4	18H	18 ^{+0.018} ₀	6 ^{+0.030} ₀	20.8	2-M5	—	—	—	—	—
19	19 ^{+0.021} ₀	5 ^{+0.050} _{+0.020}	21.0	2-M4	19H	19 ^{+0.021} ₀	6 ^{+0.030} ₀	21.8	2-M5	19N	19 ^{+0.028} _{+0.007}	6 ^{+0.030} ₀	21.8	2-M5
20	20 ^{+0.021} ₀	5 ^{+0.050} _{+0.020}	22.0	2-M4	20H	20 ^{+0.021} ₀	6 ^{+0.030} ₀	22.8	2-M5	—	—	—	—	—
22	22 ^{+0.021} ₀	7 ^{+0.061} _{+0.025}	25.0	2-M6	22H	22 ^{+0.021} ₀	6 ^{+0.030} ₀	24.8	2-M5	—	—	—	—	—
24	24 ^{+0.021} ₀	7 ^{+0.061} _{+0.025}	27.0	2-M6	24H	24 ^{+0.021} ₀	8 ^{+0.036} ₀	27.3	2-M6	24N	24 ^{+0.028} _{+0.007}	8 ^{+0.036} ₀	27.3	2-M6
25	25 ^{+0.021} ₀	7 ^{+0.061} _{+0.025}	28.0	2-M6	25H	25 ^{+0.021} ₀	8 ^{+0.036} ₀	28.3	2-M6	—	—	—	—	—
28	28 ^{+0.021} ₀	7 ^{+0.061} _{+0.025}	31.0	2-M6	28H	28 ^{+0.021} ₀	8 ^{+0.036} ₀	31.3	2-M6	28N	28 ^{+0.028} _{+0.007}	8 ^{+0.036} ₀	31.3	2-M6
30	30 ^{+0.021} ₀	7 ^{+0.061} _{+0.025}	33.0	2-M6	30H	30 ^{+0.021} ₀	8 ^{+0.036} ₀	33.3	2-M6	—	—	—	—	—
32	32 ^{+0.025} ₀	10 ^{+0.061} _{+0.025}	35.5	2-M8	32H	32 ^{+0.025} ₀	10 ^{+0.036} ₀	35.3	2-M8	—	—	—	—	—
35	35 ^{+0.025} ₀	10 ^{+0.061} _{+0.025}	38.5	2-M8	35H	35 ^{+0.025} ₀	10 ^{+0.036} ₀	38.3	2-M8	—	—	—	—	—
38	38 ^{+0.025} ₀	10 ^{+0.061} _{+0.025}	41.5	2-M8	38H	38 ^{+0.025} ₀	10 ^{+0.036} ₀	41.3	2-M8	38N	38 ^{+0.050} _{+0.025}	10 ^{+0.036} ₀	41.3	2-M8
40	40 ^{+0.025} ₀	10 ^{+0.061} _{+0.025}	43.5	2-M8	40H	40 ^{+0.025} ₀	12 ^{+0.043} ₀	43.3	2-M8	—	—	—	—	—
42	42 ^{+0.025} ₀	12 ^{+0.075} _{+0.032}	45.5	2-M8	42H	42 ^{+0.025} ₀	12 ^{+0.043} ₀	45.3	2-M8	42N	42 ^{+0.050} _{+0.025}	12 ^{+0.043} ₀	45.3	2-M8
45	45 ^{+0.025} ₀	12 ^{+0.075} _{+0.032}	48.5	2-M8	45H	45 ^{+0.025} ₀	14 ^{+0.043} ₀	48.8	2-M10	—	—	—	—	—
48	48 ^{+0.025} ₀	12 ^{+0.075} _{+0.032}	51.5	2-M8	48H	48 ^{+0.025} ₀	14 ^{+0.043} ₀	51.8	2-M10	48N	48 ^{+0.050} _{+0.025}	14 ^{+0.043} ₀	51.8	2-M10

* The ø11 or below requirement under the new JIS standards and ø11 requirement for the new motor standards are the same as the old JIS standards (class 2).

* For AL-035, the tolerance is ^{+0.05} regardless of bore diameter. The set screw size is M3.

Distance from Set Screw Edge

Model	AL-035	AL-050	AL-070	AL-075	AL-090	AL-095	AL-100	AL-110
Distance from set screw edge C [mm]	3.5	7.5	9	10	12	12	12	15

Items Checked for Design Purposes

Precautions for Handling

- Couplings are designed for use within an operating temperature from -30°C to 80°C. Although SPRFLEX couplings are designed to be waterproof and oilproof, do not subject them to excessive amounts of water or oil as these may cause deterioration. Use and storage in direct sunlight may shorten coupling service life, so cover couplings appropriately.
- To get full coupling performance, mount couplings so that differences between coupling centers during operation are within the misalignment shown in the specifications table. However, this misalignment is the maximum value when each occurs independently, so make the allowable value when they combine 50% or less of this value. Also, the maximum rotation speed does not take into account dynamic balance or mounting misalignment, so factor in the dynamic balance and mounting misalignment when using the couplings at or above 3600 min⁻¹. Be particularly careful to mount the couplings so that the mounting misalignment at rotation speeds of 2000 min⁻¹ or more is no greater than 50% or the allowable value.

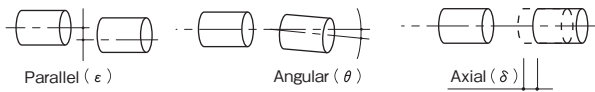

- Check centering by holding a straight-edge to the outer circumference of the main body, using two points about 90° apart. Spider service life is greatly affected by the precision of centering. We recommend matching of centering locations as the method for centering two shafts.
- Remove any rust, dust, oil or the like from the inner diameter surfaces of the shaft and coupling.
- The length of insertion of the shaft into the coupling should be the dimension L1 on the dimensions table.
- Tighten set screws with hex socket heads to the tightening torques shown below using a calibrated torque screwdriver.

Size of hex-socket-head set screw	M3	M4	M5	M6	M8	M10
Tightening torque [N·m]	0.7	1.7	3.6	6.0	14.2	28.0

Selection Procedures

- Find the torque, T_a , applied to the coupling using the output capacity, P , of the driver and the usage rotation speed, n .

$$T_a \text{ [N·m]} = 9550 \times \frac{P \text{ [kW]}}{n \text{ [min}^{-1}\text{]}}$$

- Determine the service factor K from the usage and operating conditions, and find the corrected torque, T_d , applied to the coupling.

$$T_d \text{ [N·m]} = T_a \times K1 \times K2 \times K3 \times K4$$

Service factor based on load property: K1

Load properties	Constant	Vibrations: Small	Vibrations: Medium	Vibrations: Large
K1	1.0	1.25	1.75	2.25

Service factor based on operating time: K2

Hrs./day	~ 8	~ 16	~ 24
K2	1.0	1.12	1.25

Service factor based on starting/braking frequency: K3

Times/hr.	~ 10	~ 30	~ 60	~ 120	~ 240	Over 240
K3	1.0	1.1	1.3	1.5	2.0	*

* Items marked with asterisks require consultations.

Service factor based on operating temperature: K4

Temperature [°C]	- 20	0	+ 20	+ 40	+ 60	+ 80
K4	1.3	1.1	1.0	1.1	1.3	

- Set the size so that the nominal torque of the coupling, T_n , is at least equal to the corrected torque, T_d .

$$T_n \geq T_d$$

- Select a size that results in a maximum torque, T_m , for the coupling that is at least equal to the peak torque, T_s , generated by the motor, driven machine or both. Maximum torque refers to the maximum amount of torque that can be applied for a set amount of time considering eight hours of operation per day and up to around ten instances.

$$T_m \geq T_s \cdot K4$$

- When the required shaft diameter exceeds the maximum bore diameter of the selected size, select a suitable coupling.

Induction Motor Specifications and Easy Selection Table

Motor		50 Hz: 3000 min ⁻¹ , 60 Hz: 3600 min ⁻¹				50 Hz: 1500 min ⁻¹ , 60 Hz: 1800 min ⁻¹				50 Hz: 1000 min ⁻¹ , 60 Hz: 1200 min ⁻¹			
		Two-pole motor		SPRFLEX		Four-pole motor		SPRFLEX		Six-pole motor		SPRFLEX	
Output [kW]	Frequency [Hz]	Shaft diameter [mm]	Torque [N·m]	Model	Nominal bore diameter	Shaft diameter [mm]	Torque [N·m]	Model	Nominal bore diameter	Shaft diameter [mm]	Torque [N·m]	Model	Nominal bore diameter
0.1	50	—	—	—	—	11	0.7	AL-050	11	—	—	—	—
	60	—	—	—	—	11	0.5	AL-050	11	—	—	—	—
0.2	50	11	0.7	AL-050	11	11	1.3	AL-070	11	—	—	—	—
	60	11	0.5	AL-050	11	11	1.1	AL-070	11	—	—	—	—
0.4	50	14	1.3	AL-070	14N	14	2.6	AL-075	14N	19	3.9	AL-090	19N
	60	14	1.1	AL-070	14N	14	2.2	AL-075	14N	19	3.2	AL-090	19N
0.75	50	19	2.4	AL-075	19N	19	4.9	AL-095	19N	24	7.3	AL-100	24N
	60	19	2.0	AL-075	19N	19	4.1	AL-090	19N	24	6.1	AL-095	24N
1.5	50	24	4.9	AL-095	24N	24	9.7	AL-100	24N	28	15	AL-110	28N
	60	24	4.1	AL-095	24N	24	8.1	AL-100	24N	28	12	AL-100	28N
2.2	50	24	7.1	AL-100	24N	28	14	AL-110	28N	28	21	AL-110	28N
	60	24	6.0	AL-095	24N	28	12	AL-100	28N	28	18	AL-110	28N
3.7	50	28	12	AL-100	28N	28	24	AL-110	28N	38	36	—	38N
	60	28	10	AL-100	28N	28	20	AL-110	28N	38	30	AL-110	38N

* The above table shows suitable sizes for ordinary use on an induction motor drive unit.
* Motor rotation speed and output torque are calculated (reference) values.

MODELS

AL



ABSSAC

PRECISION MOTION SINCE 1982

Call: 01386 421 005
Fax: 01386 422 441
Email: sales@abssac.co.uk
Web: www.abssac.co.uk

ABSSAC Ltd,
E1A The Enterprise Centre,
Enterprise Way, Evesham,
Worcestershire.
United Kingdom.
WR11 1GS