

KB1 Miniature metal bellow coupling

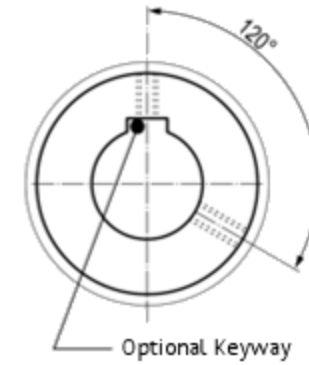
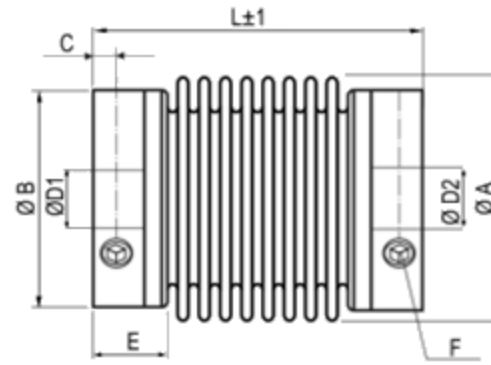

Size	Torque (Nm)	Dimensions (mm)							Technical Specification							
		L	A	D1/D2	B	C	E	F	Mass (g)	Moment of inertia g.m ²	Bellows stiffness			Offset		
		Length	Diameter	Bores	Diameter		Hub Length	Bolt Torque			Torsion Nm/rad (10 ³)	Radial N/mm	Axial N/mm	Radial mm	Axial mm	Angle Degrees
5	0.05	14	6.5	1-3	6.5	1.5	4	1 x M2 0.35	1	0.1	50	6	9	0.1	0.4	1
1	0.1	23	10	1-4	10	2	6	1 x M3 0.5	3	0.45	65	10	14	0.12	0.2	1.2
5	0.5	19	15	3-8	13.5	2	6	1 x M3 0.5	4	1.3	260	43	13	0.1	0.2	1
		4.5							1.5	200	18	10	0.15	0.3	1.5	
		5							1.6	160	9	8	0.2	0.4	2	
10	1	21	15	3-8	13.5	2	6	1 x M3 0.5	5.5	1.8	510	74	27	0.1	0.2	1
		6							2	380	31	20	0.15	0.3	1.5	
		7							2.3	310	16	16	0.2	0.4	2	
15	1.5	26	19	3-12	19	3	8	2 x M4	10	6	750	59	15	0.1	0.3	1.5
		30		8#				1.5	12	7.4	700	20	9	0.15	0.4	2
20	2	22	24	3-14	21.5	3	6	2 x M4	11	9.2	1500	67	12	0.15	0.3	1.5
		28		10#				1.5	13	12.6	1300	21	11	0.2	0.4	1.5
		32		1.5				15	13.5	1050	11	9	0.25	0.5	2	
45	4.5	40	32	6-19	29	4	12	2 x M6	44	68	6500	168	32	0.1	0.3	1.5
		48		13#				3	50	79	4200	41	20	0.2	0.5	2
100	10	45	40	6-24	36	4	12	2 x M6	60	150	8100	120	27	0.15	0.4	1.5
		55		17#				3	79	210	6800	29	17	0.3	0.6	2

Standard Product Order Number: **KB1 / 45 - 40 - 10 - 18**

Bellows Range ————
 Size ————
 Length ————
 Bore 1 ————
 Bore 2 ————

Rotational Speed: Max 15000 Min²
 Material: Bellows - Stainless Steel
 Size 05 - Bronze
 Hub - Aluminium
 Hub: Tolerance H7
 Temperature: -30°C ~ 120°C
 Keyway: optional Keyways to DIN 6885
 Largest Possible bore marked with #