



Single Nut with Flange



Precision Ball Screws

Single Nut with Flange

Backlash type/Preload type

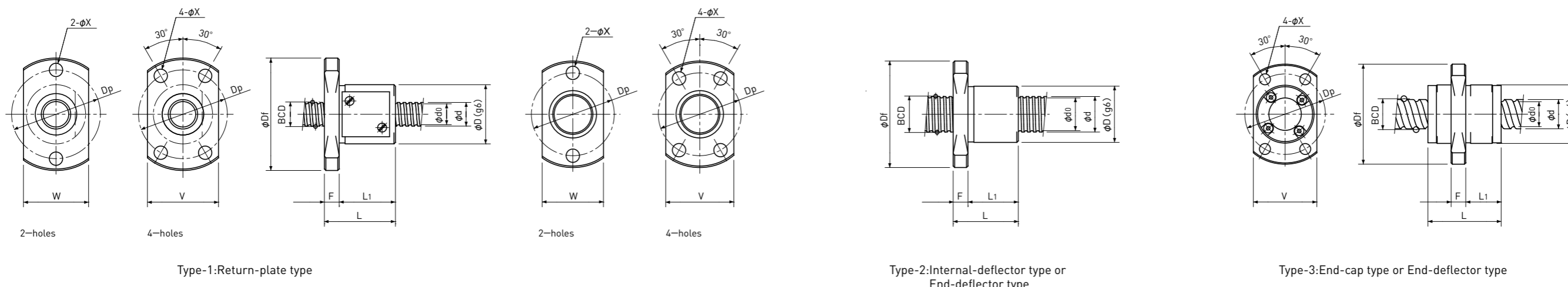

Unit: mm

Ball Nut Model number	Shaft nominal dia. d	Lead	Ball size	BCD	Lead angle	Root dia. d ₀	Number of Circuit	Basic Load Rating			Nut Rigidity N/μm	Nut dimension								Ball Nut Model number		
								N		N/μm		Nut type	D	Df	L	L ₁	F	W	V		Dp	Bolt Hole X
								Dynamic Ca	Static Coa													
FBS 01800.5 A	1.8	0.5	0.4	1.95	4° 40'	1.5	2.7×1	110 / -	130 / -	19 / -	1	6	14	8.5	7	1.5	8	-	10	2.4	FBS 01800.5 A	
FBS 0300.5 A	3	0.5	0.4	3.10	2° 56'	2.6	2.7×1	150 / -	220 / -	29 / -	1	8	16	11	8	3	8	-	12	2.4	FBS 0300.5 A	
FBS 0301 B	3	1	0.6	3.18	5° 43'	2.4	3.7×1	330 / -	440 / -	42 / -	1	9	19	14	11	3	11	-	14	2.9	FBS 0301 B	
FBS 0400.5 A	4	0.5	0.4	4.10	2° 13'	3.6	2.7×1	160 / -	290 / -	36 / -	1	10	20	13	10	3	12	-	15	2.9	FBS 0400.5 A	
FKB 0401 A	4	1	0.6	4.15	4° 23'	3.4	1×3	300 / 300	430 / 430	38 / 59	2	9	19	13	10	3	11	13	14	2.9	FKB 0401 A	
FBS 0401 A	4	1	0.8	4.15	4° 23'	3.3	2.7×1	420 / 270	570 / 290	40 / 34	1	10	20	12	9	3	12	14	15	2.9	FBS 0401 A	
FBS 0401 B	4	1	0.8	4.15	4° 23'	3.3	3.7×1	560 / 350	790 / 400	54 / 45	1	11	23	17	13	4	13	15	17	3.4	FBS 0401 B	
FBS 0402 A	4	2	0.8	4.15	8° 43'	3.3	2.7×1	420 / 260	570 / 290	39 / 33	1	11	23	19	15	4	13	15	17	3.4	FBS 0402 A	
FBS 0403 A	4	3	0.8	4.15	12° 57'	3.3	2.7×1	420 / -	570 / -	39 / -	1	11	23	21	17	4	13	15	17	3.4	FBS 0403 A	
FEB 0404 A	4	4	0.8	4.2	16° 51'	3.3	2.6×2	750 / -	1150 / -	73 / -	3	11	23	17.5	11	3	-	15	17	3.4	FEB 0404 A	

Basic Load Rating		Nut Rigidity N/μm
N		
Dynamic Ca	Static Coa	164 / 138
1000 / 640	3300 / 1650	

Preload type
Backlash type

- Note 1) The diameter of one of the Screw Shaft ends must be less than the Screw Shaft Root diameter, otherwise Ball Nut cannot be installed.
- Note 2) Ball Nut dimension is without seal at the both ends. If the seals are required, Ball Nut dimension should be changed, in that case, please ask KSS. Some type of Ball Nuts cannot equip with seals, please ask KSS representative.
- Note 3) The Rigidity values shown in the table are theoretical values of Ball Nut Rigidity calculated from the amount of Elastic Displacement under the following conditions. Backlash type ; Apply the Axial load equivalent to 30% of the Basic Dynamic Load Rating Ca. Preload type ; Apply the Preload equivalent to 5% of the Basic Dynamic Load Rating Ca. For Axial load or Preload condition other than the above, see the formula in p-A823, you can calculate Rigidity using this formula.
- Note 4) All models are Right-hand Screw. If Left-hand Screw is required, please ask KSS representative.
- Note 5) Basic Load Rating and Rigidity for Backlash type and Preload type are described in the same cell.



Precision Ball Screws

Single Nut with Flange

Backlash type/Preload type

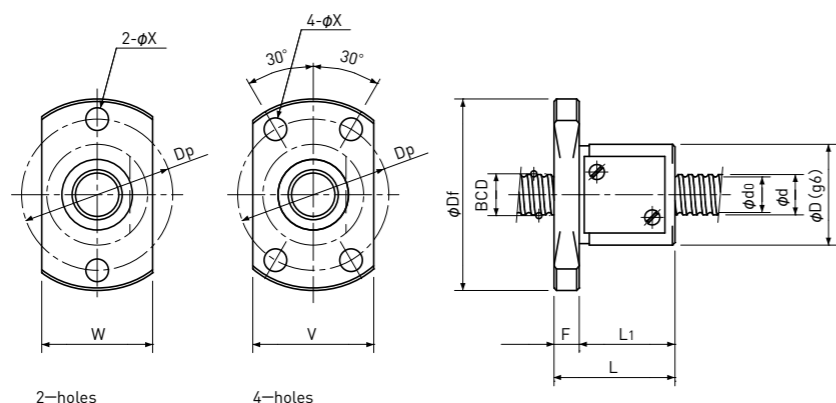

Type-1:Return-plate type

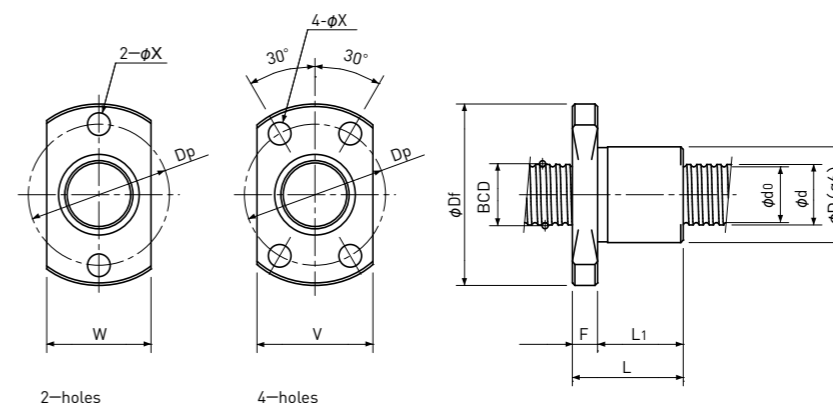

Type-2:Internal-deflector type or End-deflector type

Unit: mm

Ball Nut Model number	Shaft nominal dia. d	Lead	Ball size	BCD	Lead angle	Root dia. d ₀	Number of Circuit	Basic Load Rating		Nut Rigidity N/μm	Nut dimension									Ball Nut Model number	
								N			D	Df	L	L ₁	F	W	V	Dp	Bolt Hole X		
								Dynamic Ca	Static Coa												
FBS 0500.5 A	5	0.5	0.4	5.10	1°47'	4.6	2.7×1	180 / -	370 / -	44 / -	1	11	23	13	10	3	13	-	17	3.4	FBS 0500.5 A
FKB 0501 A	5	1	0.6	5.15	3°32'	4.4	1×3	330 / 330	560 / 560	45 / 70	2	10	20	13	10	3	12	14	15	2.9	FKB 0501 A
FBS 0501 B	5	1	0.8	5.15	3°32'	4.3	3.7×1	630 / 400	1000 / 500	65 / 55	1	12	24	17	13	4	14	15	18	3.4	FBS 0501 B
FBS 0504 A	5	4	0.8	5.15	13°53'	4.3	2.7×1	470 / 300	720 / 360	47 / 39	1	12	24	22	18	4	14	15	18	3.4	FBS 0504 A

Basic Load Rating		Nut Rigidity N/μm
Dynamic	Static	
Ca	Coa	164 / 138
1000 / 640	3300 / 1650	

Preload type
Backlash type

- Note 1) The diameter of one of the Screw Shaft ends must be less than the Screw Shaft Root diameter, otherwise Ball Nut cannot be installed.
- Note 2) Ball Nut dimension is without seal at the both ends.
If the seals are required, Ball Nut dimension should be changed, in that case, please ask KSS.
Some type of Ball Nuts cannot equip with seals, please ask KSS representative.
- Note 3) The Rigidity values shown in the table are theoretical values of Ball Nut Rigidity calculated from the amount of Elastic Displacement under the following conditions.
Backlash type ; Apply the Axial load equivalent to 30% of the Basic Dynamic Load Rating Ca.
Preload type ; Apply the Preload equivalent to 5% of the Basic Dynamic Load Rating Ca.
For Axial load or Preload condition other than the above, see the formula in p-A823, you can calculate Rigidity using this formula.
- Note 4) All models are Right-hand Screw. If Left-hand Screw is required, please ask KSS representative.
- Note 5) Basic Load Rating and Rigidity for Backlash type and Preload type are described in the same cell.



Precision Ball Screws

Single Nut with Flange

Backlash type/Preload type

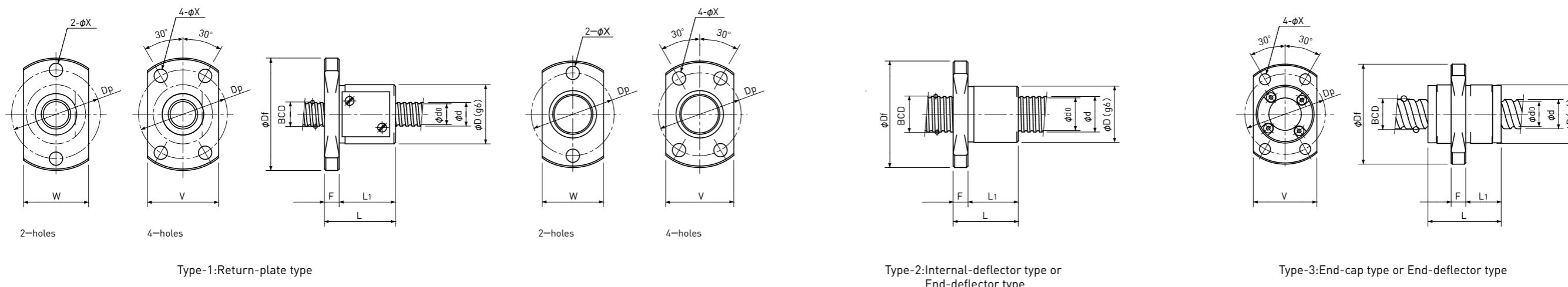

Unit: mm

Ball Nut Model number	Shaft nominal dia. d	Lead	Ball size	BCD	Lead angle	Root dia. d ₀	Number of Circuit	Basic Load Rating			Nut Rigidity N/μm	Nut dimension									Ball Nut Model number	
								N		N/μm		Nut type	D	Df	L	L ₁	F	W	V	Dp		Bolt Hole X
								Dynamic	Static													
								Ca	Coa													
FBS 0600.5 A	6	0.5	0.4	6.10	1°30'	5.6	2.7×1	190 / -	440 / -	50 / -	1	12	25	13	10	3	14	-	19	3.4	FBS 0600.5 A	
FKB 0601 A	6	1	0.8	6.20	2°56'	5.3	1×3	560 / 560	950 / 950	55 / 86	2	11	23	14.5	11	3.5	13	15	17	3.4	FKB 0601 A	
FBS 0601 B	6	1	0.8	6.15	2°58'	5.3	3.7×1	680 / 430	1200 / 610	75 / 63	1	13	28	17	13	4	15	17	21.5	3.4	FBS 0601 B	
FBS 0601.5 B	6	1.5	1.0	6.20	4°24'	5.1	3.7×1	980 / 620	1600 / 800	79 / 67	1	14	28	19	15	4	16	17	22	3.4	FBS 0601.5 B	
FBS 0602 A	6	2	1.0	6.20	5°52'	5.1	2.7×1	750 / 470	1200 / 590	58 / 49	1	15	29	17	13	4	17	18	23	3.4	FBS 0602 A	
FBS 0602 B	6	2	1.0	6.20	5°52'	5.1	3.7×1	980 / 620	1600 / 800	79 / 67	1	15	29	21	17	4	17	18	23	3.4	FBS 0602 B	
FBS 0602.5 A	6	2.5	1.0	6.20	7°19'	5.1	2.7×1	750 / 470	1200 / 590	59 / 49	1	15	29	18	14	4	17	18	23	3.4	FBS 0602.5 A	
FEB 0606 A	6	6	1.0	6.30	16°52'	5.2	1.6×2	870 / -	1450 / -	67 / -	3	14	27	17	8	4	-	16	21	3.4	FEB 0606 A	
FEB 0610 A	6	10	1.2	6.30	26°48'	5.0	1.2×2	950 / -	1600 / -	50 / -	3	14	27	23	11.5	4	-	16	21	3.4	FEB 0610 A	
FEB 0612 A	6	12	1.2	6.30	31°13'	5.0	0.7×2	600 / -	950 / -	29 / -	3	14	27	16	8.3	4	-	16	21	3.4	FEB 0612 A	

Basic Load Rating		Nut Rigidity N/μm
N		
Dynamic	Static	
Ca	Coa	164 / 138
1000 / 640	3300 / 1650	

Preload type
Backlash type

- Note 1) The diameter of one of the Screw Shaft ends must be less than the Screw Shaft Root diameter, otherwise Ball Nut cannot be installed.
- Note 2) Ball Nut dimension is without seal at the both ends. If the seals are required, Ball Nut dimension should be changed, in that case, please ask KSS. Some type of Ball Nuts cannot equip with seals, please ask KSS representative.
- Note 3) The Rigidity values shown in the table are theoretical values of Ball Nut Rigidity calculated from the amount of Elastic Displacement under the following conditions. Backlash type ; Apply the Axial load equivalent to 30% of the Basic Dynamic Load Rating Ca. Preload type ; Apply the Preload equivalent to 5% of the Basic Dynamic Load Rating Ca. For Axial load or Preload condition other than the above, see the formula in p-A823, you can calculate Rigidity using this formula.
- Note 4) All models are Right-hand Screw. If Left-hand Screw is required, please ask KSS representative.
- Note 5) Basic Load Rating and Rigidity for Backlash type and Preload type are described in the same cell.



Precision Ball Screws

Single Nut with Flange

Backlash type/Preload type

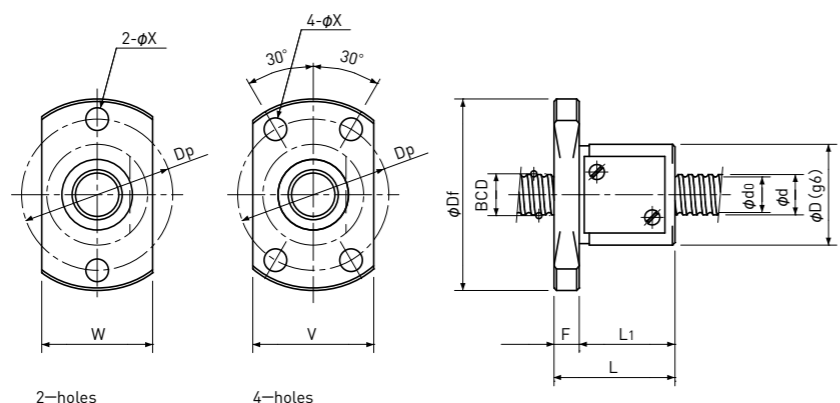

Type-1:Return-plate type

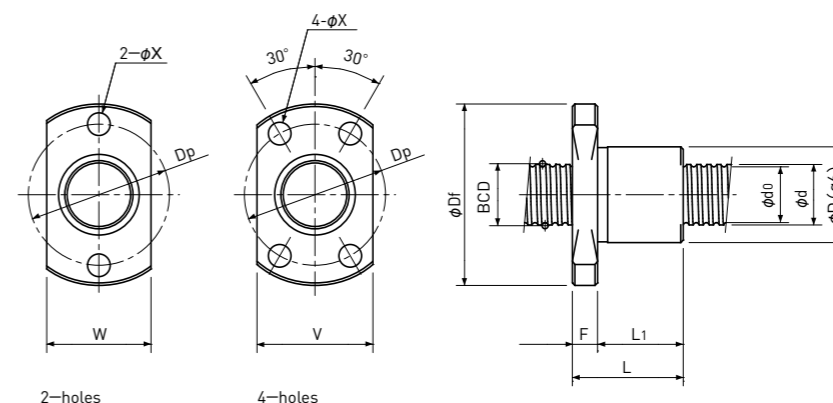

Type-2:Internal-deflector type or End-deflector type

Unit: mm

Ball Nut Model number	Shaft nominal dia. d	Lead リード	Ball size	BCD	Lead angle	Root dia. d ₀	Number of Circuit	Basic Load Rating		Nut Rigidity N/μm	Nut dimension									Ball Nut Model number	
								N			Nut type	D	Df	L	L ₁	F	W	V	Dp		Bolt Hole X
								Dynamic Ca	Static Coa												
FBS 0800.5 A	8	0.5	0.4	8.10	1°08'	7.6	2.7×1	220 / -	590 / -	64 / -	1	14	27	13	10	3	16	-	21	3.4	FBS 0800.5 A
FKB 0801 A	8	1	0.8	8.20	2°13'	7.3	1×3	650 / 650	1300 / 1300	70 / 109	2	13	26	15	11	4	15	17	20	3.4	FKB 0801 A
FBS 0801 B	8	1	0.8	8.15	2°15'	7.3	3.7×1	780 / 490	1650 / 820	95 / 80	1	16	30	17	13	4	18	18	24	3.4	FBS 0801 B
FKB 0801.5 A	8	1.5	1.0	8.30	3°18'	7.2	1×3	890 / 890	1650 / 1650	73 / 113	2	15	28	20	16	4	17	19	22	3.4	FKB 0801.5 A
FBS 0801.5 B	8	1.5	1.0	8.20	3°20'	7.1	3.7×1	1100 / 700	2200 / 1100	99 / 83	1	16	30	19	15	4	18	18	24	3.4	FBS 0801.5 B
FKB 0802 A	8	2	1.2	8.30	4°23'	7.0	1×3	1300 / 1300	2300 / 2300	77 / 121	2	15	28	18	14	4	17	19	22	3.4	FKB 0802 A
FBS 0802 A(1)	8	2	1.0	8.20	4°26'	7.1	2.7×1	850 / 540	1600 / 800	74 / 61	1	16	30	17	13	4	18	18	24	3.4	FBS 0802 A(1)
FBS 0802 B(1)	8	2	1.0	8.20	4°26'	7.1	3.7×1	1100 / 700	2200 / 1100	99 / 83	1	16	30	21	17	4	18	18	24	3.4	FBS 0802 B(1)
FBS 0802 A(2)	8	2	1.5875	8.30	4°23'	6.6	2.7×1	1850 / 1150	3000 / 1500	82 / 69	1	20	38	21	16	5	22	23	30	4.5	FBS 0802 A(2)
FBS 0802 B(2)	8	2	1.5875	8.30	4°23'	6.6	3.7×1	2400 / 1550	4100 / 2100	111 / 94	1	20	38	24	19	5	22	23	30	4.5	FBS 0802 B(2)

Basic Load Rating		Nut Rigidity N/μm
Dynamic Ca	Static Coa	
1000 / 640	3300 / 1650	164 / 138
		Preload type
		Backlash type

- Note 1) The diameter of one of the Screw Shaft ends must be less than the Screw Shaft Root diameter, otherwise Ball Nut cannot be installed.
- Note 2) Ball Nut dimension is without seal at the both ends.
If the seals are required, Ball Nut dimension should be changed, in that case, please ask KSS.
Some type of Ball Nuts cannot equip with seals, please ask KSS representative.
- Note 3) The Rigidity values shown in the table are theoretical values of Ball Nut Rigidity calculated from the amount of Elastic Displacement under the following conditions.
Backlash type ; Apply the Axial load equivalent to 30% of the Basic Dynamic Load Rating Ca.
Preload type ; Apply the Preload equivalent to 5% of the Basic Dynamic Load Rating Ca.
For Axial load or Preload condition other than the above, see the formula in p-A823, you can calculate Rigidity using this formula.
- Note 4) All models are Right-hand Screw. If Left-hand Screw is required, please ask KSS representative.
- Note 5) Basic Load Rating and Rigidity for Backlash type and Preload type are described in the same cell.



Precision Ball Screws

Single Nut with Flange

Backlash type/Preload type

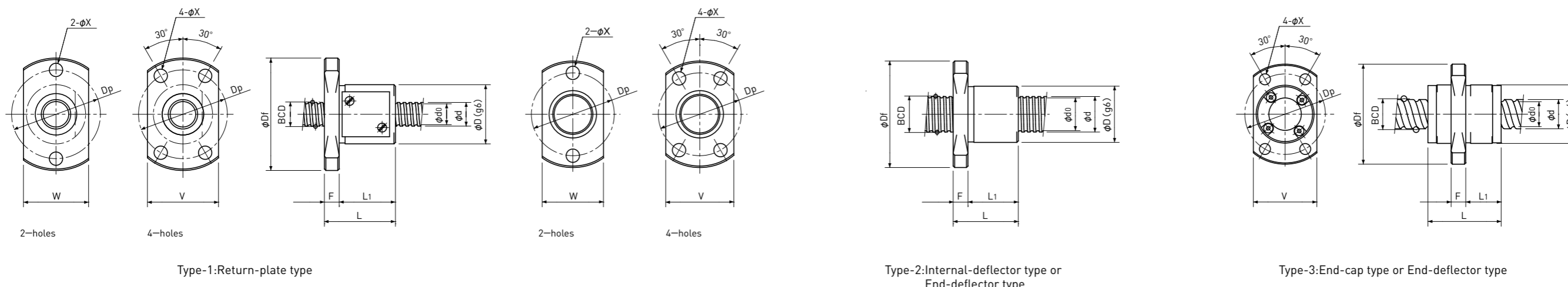

Unit: mm

Ball Nut Model number	Shaft nominal dia. d	Lead	Ball size	BCD	Lead angle	Root dia. d ₀	Number of Circuit	Basic Load Rating			Nut Rigidity N/μm	Nut dimension									Ball Nut Model number	
								N		N/μm		Nut type	D	Df	L	L ₁	F	W	V	Dp		Bolt Hole X
								Dynamic	Static													
								Ca	Coa													
FDB 0802.5 A	8	2.5	1.5875	8.00	5° 41'	6.3	2.7×1	1850 / -	3000 / -	80 / -	2	16	29	16	12	4	-	18	23	3.4	FDB 0802.5 A	
FBS 0802.5 A	8	2.5	1.5875	8.30	5° 29'	6.6	2.7×1	1850 / 1150	3000 / 1500	82 / 69	1	20	38	23	18	5	22	23	30	4.5	FBS 0802.5 A	
FBS 0802.5 B	8	2.5	1.5875	8.30	5° 29'	6.6	3.7×1	2400 / 1550	4100 / 2100	111 / 93	1	20	38	26	21	5	22	23	30	4.5	FBS 0802.5 B	
FBS 0803 A	8	3	2.0	8.30	6° 34'	6.2	2.7×1	2600 / 1650	4200 / 2100	85 / 70	1	20	38	25	20	5	22	23	30	4.5	FBS 0803 A	
FBS 0803 B	8	3	2.0	8.30	6° 34'	6.2	3.7×1	3500 / 2200	5700 / 2800	116 / 97	1	20	38	29	24	5	22	23	30	4.5	FBS 0803 B	
FBS 0804 A	8	4	2.0	8.30	8° 43'	6.2	2.7×1	2600 / 1650	4200 / 2100	84 / 70	1	21	39	28	23	5	23	23	31	4.5	FBS 0804 A	
FBS 0805 A	8	5	1.5875	8.30	10° 51'	6.6	2.7×1	1850 / 1150	3000 / 1500	82 / 67	1	18	31	28	24	4	20	20	25	3.4	FBS 0805 A	
FEB 0808 A	8	8	1.5875	8.40	16° 52'	6.7	1.6×2	2200 / -	3800 / -	95 / -	3	18	31	20	10	4	-	20	25	3.4	FEB 0808 A	
FEB 0810 A	8	10	1.5875	8.40	20° 45'	6.7	1.6×2	2200 / -	3900 / -	92 / -	3	18	31	24	13	4	-	20	25	3.4	FEB 0810 A	
FEB 0812 A	8	12	1.5875	8.40	24° 27'	6.7	1.6×2	2200 / -	4000 / -	90 / -	3	18	31	27	17	4	-	20	25	3.4	FEB 0812 A	

Basic Load Rating		Nut Rigidity N/μm
Dynamic	Static	
Ca	Coa	N/μm
1000 / 640	3300 / 1650	164 / 138
		Preload type
		Backlash type

- Note 1) The diameter of one of the Screw Shaft ends must be less than the Screw Shaft Root diameter, otherwise Ball Nut cannot be installed.
- Note 2) Ball Nut dimension is without seal at the both ends. If the seals are required, Ball Nut dimension should be changed, in that case, please ask KSS. Some type of Ball Nuts cannot equip with seals, please ask KSS representative.
- Note 3) The Rigidity values shown in the table are theoretical values of Ball Nut Rigidity calculated from the amount of Elastic Displacement under the following conditions. Backlash type ; Apply the Axial load equivalent to 30% of the Basic Dynamic Load Rating Ca. Preload type ; Apply the Preload equivalent to 5% of the Basic Dynamic Load Rating Ca. For Axial load or Preload condition other than the above, see the formula in p-A823, you can calculate Rigidity using this formula.
- Note 4) All models are Right-hand Screw. If Left-hand Screw is required, please ask KSS representative.
- Note 5) Basic Load Rating and Rigidity for Backlash type and Preload type are described in the same cell.



Precision Ball Screws

Single Nut with Flange

Backlash type/Preload type

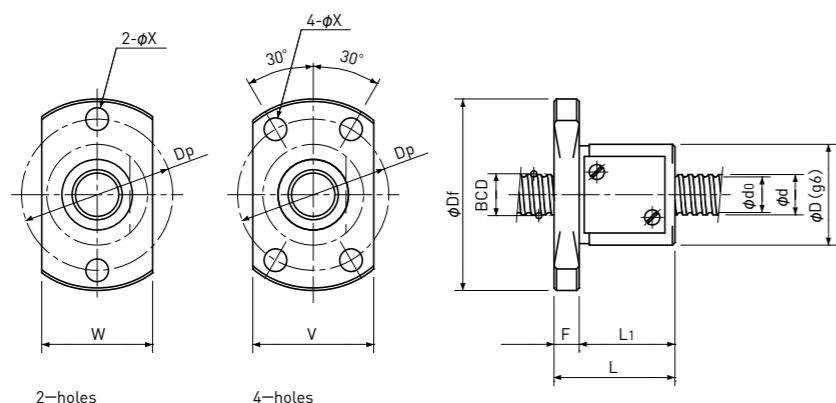

Type-1:Return-plate type

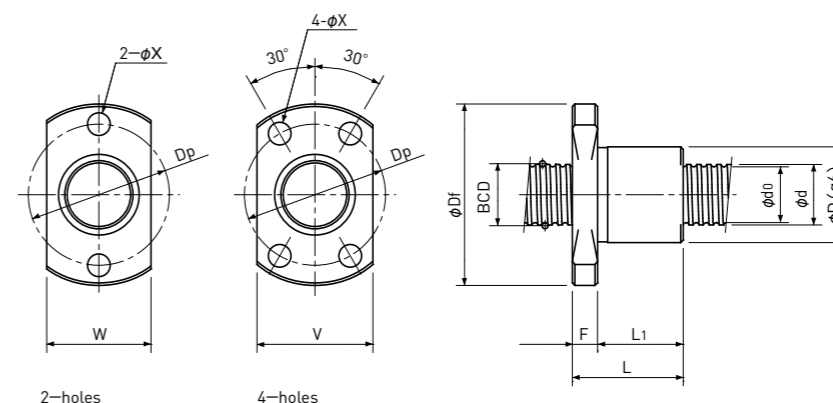

Type-2:Internal-deflector type or End-deflector type

Unit: mm

Ball Nut Model number	Shaft nominal dia. d	Lead	Ball size	BCD	Lead angle	Root dia. d ₀	Number of Circuit	Basic Load Rating		Nut Rigidity N/μm	Nut dimension									Ball Nut Model number	
								N			Nut type	D	Df	L	L ₁	F	W	V	Dp		Bolt Hole X
								Dynamic Ca	Static Coa												
FKB 1001 A	10	1	0.8	10.20	1°47'	9.3	1×3	720 / 720	1650 / 1650	84 / 131	2	15	28	15	11	4	17	19	22	3.4	FKB 1001 A
FBS 1001 B	10	1	0.8	10.15	1°48'	9.3	3.7×1	840 / 530	2000 / 1000	113 / 95	1	19	37	18	13	5	21	22	29	4.5	FBS 1001 B
FKB 1001.5 A	10	1.5	1.0	10.30	2°39'	9.2	1×3	990 / 990	2100 / 2100	87 / 136	2	17	34	21	16	5	19	21	26	4.5	FKB 1001.5 A
FBS 1001.5 B	10	1.5	1.0	10.20	2°41'	9.1	3.7×1	1250 / 790	2800 / 1400	120 / 101	1	19	37	20	15	5	21	22	29	4.5	FBS 1001.5 B
FKB 1002 A	10	2	1.2	10.30	3°32'	9.0	1×3	1450 / 1450	3000 / 3000	93 / 144	2	17	34	19	14	5	19	21	26	4.5	FKB 1002 A
FBS 1002 A	10	2	1.5875	10.30	3°32'	8.6	2.7×1	2100 / 1300	3800 / 1900	100 / 82	1	23	41	21	16	5	25	25	33	4.5	FBS 1002 A
FBS 1002 B	10	2	1.5875	10.30	3°32'	8.6	3.7×1	2700 / 1750	5300 / 2700	134 / 112	1	23	41	24	19	5	25	25	33	4.5	FBS 1002 B
FKB 1002.5 A	10	2.5	1.5875	10.40	4°23'	8.7	1×3	2100 / 2100	3800 / 3800	96 / 150	2	18	35	21	16	5	20	22	27	4.5	FKB 1002.5 A
FBS 1002.5 A	10	2.5	1.5875	10.30	4°25'	8.6	2.7×1	2100 / 1300	3800 / 1900	100 / 82	1	24	44	24	18	6	26	27	35	5.5	FBS 1002.5 A
FBS 1002.5 B	10	2.5	1.5875	10.30	4°25'	8.6	3.7×1	2700 / 1750	5300 / 2700	133 / 112	1	24	44	27	21	6	26	27	35	5.5	FBS 1002.5 B

Basic Load Rating		Nut Rigidity N/μm
Dynamic Ca	Static Coa	
1000 / 640	3300 / 1650	164 / 138
		Preload type
		Backlash type

- Note 1) The diameter of one of the Screw Shaft ends must be less than the Screw Shaft Root diameter, otherwise Ball Nut cannot be installed.
- Note 2) Ball Nut dimension is without seal at the both ends.
If the seals are required, Ball Nut dimension should be changed, in that case, please ask KSS.
Some type of Ball Nuts cannot equip with seals, please ask KSS representative.
- Note 3) The Rigidity values shown in the table are theoretical values of Ball Nut Rigidity calculated from the amount of Elastic Displacement under the following conditions.
Backlash type ; Apply the Axial load equivalent to 30% of the Basic Dynamic Load Rating Ca.
Preload type ; Apply the Preload equivalent to 5% of the Basic Dynamic Load Rating Ca.
For Axial load or Preload condition other than the above, see the formula in p-A823, you can calculate Rigidity using this formula.
- Note 4) All models are Right-hand Screw. If Left-hand Screw is required, please ask KSS representative.
- Note 5) Basic Load Rating and Rigidity for Backlash type and Preload type are described in the same cell.



Precision Ball Screws

Single Nut with Flange

Backlash type/Preload type

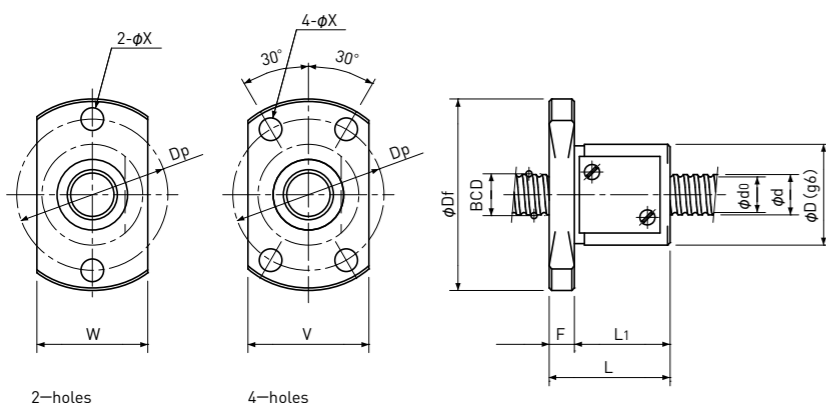

Type-1:Return-plate type

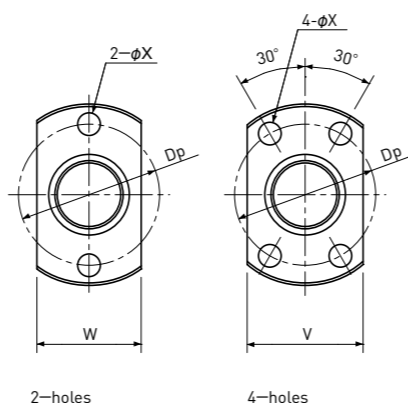

Type-2:Internal-deflector type or End-deflector type

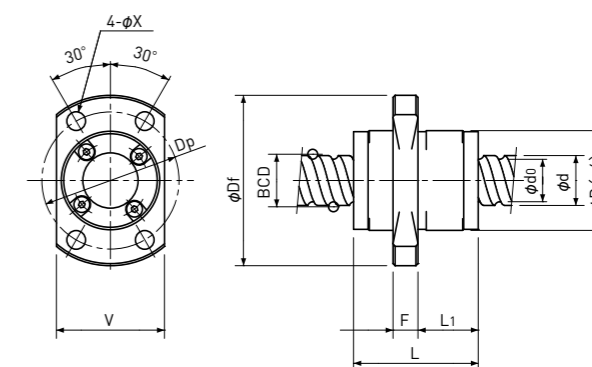

Type-3:End-cap type or End-deflector type

Unit: mm

Ball Nut Model number	Shaft nominal dia. d	Lead	Ball size	BCD	Lead angle	Root dia. d ₀	Number of Circuit	Basic Load Rating		Nut Rigidity N/μm	Nut dimension										Ball Nut Model number
								N			D	Df	L	L ₁	F	W	V	Dp	Bolt Hole X		
								Dynamic Ca	Static Coa												
FBS 1003 A	10	3	2.0	10.30	5° 18'	8.2	2.7×1	3000 / 1800	5200 / 2600	103 / 84	1	24	44	26	20	6	26	27	35	5.5	FBS 1003 A
FBS 1003 B	10	3	2.0	10.30	5° 18'	8.2	3.7×1	3900 / 2500	7200 / 3600	140 / 118	1	24	44	30	24	6	26	27	35	5.5	FBS 1003 B
FBS 1004 A	10	4	2.0	10.30	7° 03'	8.2	2.7×1	3000 / 1800	5200 / 2600	104 / 86	1	24	44	29	23	6	26	27	35	5.5	FBS 1004 A
FBS 1004 B	10	4	2.0	10.30	7° 03'	8.2	3.7×1	3900 / 2500	7200 / 3600	139 / 118	1	24	44	33	27	6	26	27	35	5.5	FBS 1004 B
FDB 1005 A	10	5	2.0	10.30	8° 47'	8.2	2.7×1	3000 / -	5200 / -	103 / -	2	23	40	26	21	5	-	25	32	4.5	FDB 1005 A
FBS 1005 A	10	5	2.0	10.30	8° 47'	8.2	2.7×1	3000 / 1800	5200 / 2600	103 / 85	1	24	44	34	28	6	26	27	35	5.5	FBS 1005 A
FEB 1010 A	10	10	2.0	10.50	16° 52'	8.4	1.6×2	3300 / -	5900 / -	117 / -	3	23	40	24	13	5	-	25	32	4.5	FEB 1010 A
FEB 1012 A	10	12	2.0	10.50	19° 59'	8.4	1.6×2	3300 / -	6200 / -	115 / -	3	23	40	28	17	5	-	25	32	4.5	FEB 1012 A
FEB 1015 A	10	15	2.0	10.50	24° 27'	8.4	1.6×2	3300 / -	6400 / -	110 / -	3	23	40	33	22	5	-	25	32	4.5	FEB 1015 A
FEB 1020 A	10	20	1.5875	10.40	31° 28'	8.7	0.7×4	2100 / -	4000 / -	88 / -	3	20	37	23	13	5	-	22	29	4.5	FEB 1020 A
FEB 1025 A	10	25	1.5875	10.40	37° 25'	8.7	0.7×4	2100 / -	4000 / -	82 / -	3	20	37	27.5	17.5	5	-	22	29	4.5	FEB 1025 A
FEB 1030 A	10	30	1.5875	10.40	42° 33'	8.7	0.7×4	2100 / -	4000 / -	76 / -	3	20	37	31.5	21.7	5	-	22	29	4.5	FEB 1030 A

Basic Load Rating		Nut Rigidity N/μm
Dynamic Ca	Static Coa	
1000 / 640	3300 / 1650	164 / 138
		Preload type
		Backlash type

- Note 1) The diameter of one of the Screw Shaft ends must be less than the Screw Shaft Root diameter, otherwise Ball Nut cannot be installed.
- Note 2) Ball Nut dimension is without seal at the both ends.
If the seals are required, Ball Nut dimension should be changed, in that case, please ask KSS.
Some type of Ball Nuts cannot equip with seals, please ask KSS representative.
- Note 3) The Rigidity values shown in the table are theoretical values of Ball Nut Rigidity calculated from the amount of Elastic Displacement under the following conditions.
Backlash type ; Apply the Axial load equivalent to 30% of the Basic Dynamic Load Rating Ca.
Preload type ; Apply the Preload equivalent to 5% of the Basic Dynamic Load Rating Ca.
For Axial load or Preload condition other than the above, see the formula in p-A823, you can calculate Rigidity using this formula.
- Note 4) All models are Right-hand Screw. If Left-hand Screw is required, please ask KSS representative.
- Note 5) Basic Load Rating and Rigidity for Backlash type and Preload type are described in the same cell.



Precision Ball Screws

Single Nut with Flange

Backlash type/Preload type

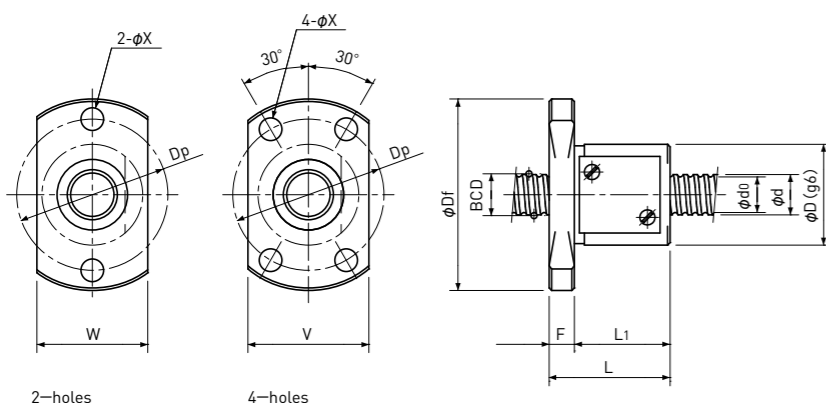

Type-1:Return-plate type

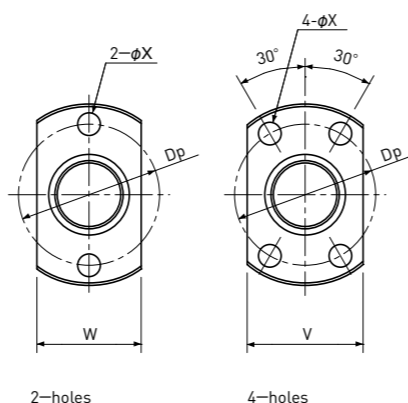

Type-2:Internal-deflector type or End-deflector type

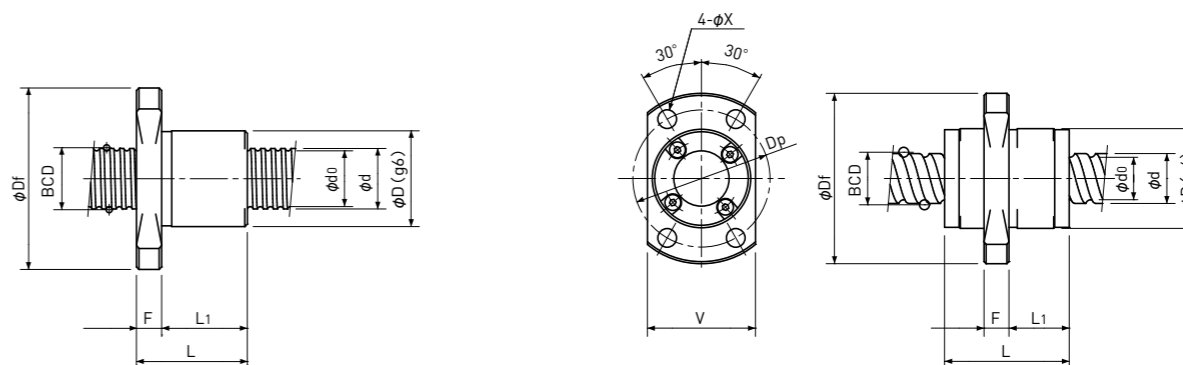

Type-3:End-cap type or End-deflector type

Unit: mm

Ball Nut Model number	Shaft nominal dia. d	Lead	Ball size	BCD	Lead angle	Root dia. d ₀	Number of Circuit	Basic Load Rating		Nut Rigidity N/μm	Nut dimension										Ball Nut Model number
								N			D	Df	L	L ₁	F	W	V	Dp	Bolt Hole X		
								Dynamic Ca	Static Coa												
FKB 1201 A	12	1	0.8	12.20	1°30'	11.3	1×3	780 / 780	2000 / 2000	97 / 152	2	17	34	16	11	5	19	21	26	4.5	FKB 1201 A
FBS 1201 B	12	1	0.8	12.15	1°30'	11.3	3.7×1	910 / 570	2400 / 1200	131 / 110	1	22	40	18	13	5	24	24	32	4.5	FBS 1201 B
FKB 1202 A	12	2	1.2	12.30	2°58'	11.0	1×3	1600 / 1600	3700 / 3700	109 / 169	2	19	36	19	14	5	21	23	28	4.5	FKB 1202 A
FBS 1202 B	12	2	1.5875	12.30	2°58'	10.6	3.7×1	3000 / 1900	6400 / 3200	156 / 132	1	25	45	25	19	6	27	27	36	5.5	FBS 1202 B
FKB 1202.5 A	12	2.5	1.5875	12.40	3°41'	10.7	1×3	2300 / 2300	4700 / 4700	112 / 174	2	20	37	21	16	5	22	24	29	4.5	FKB 1202.5 A
FBS 1202.5 B	12	2.5	1.5875	12.30	3°42'	10.6	3.7×1	3000 / 1850	6400 / 3200	156 / 130	1	26	46	27	21	6	28	28	37	5.5	FBS 1202.5 B
FKB 1203 A	12	3	2.0	12.50	4°22'	10.4	1×3	3100 / 3100	5700 / 5700	115 / 179	2	22	41	32	26	6	24	26	32	5.5	FKB 1203 A
FBS 1203 B	12	3	2.0	12.30	4°26'	10.2	3.7×1	4300 / 2800	8700 / 4300	162 / 137	1	28	48	30	24	6	30	30	39	5.5	FBS 1203 B
FBS 1204 B	12	4	2.381	12.30	5°55'	9.8	3.7×1	5400 / 3400	10200 / 5100	165 / 139	1	28	48	33	27	6	30	30	39	5.5	FBS 1204 B
FBS 1205 A	12	5	2.381	12.30	7°22'	9.8	2.7×1	4100 / 2500	7400 / 3700	122 / 101	1	28	48	33	27	6	30	30	39	5.5	FBS 1205 A
FEB 1210 A	12	10	2.381	12.65	14°7'	10.2	1.7×2	5100 / -	9800 / -	152 / -	3	24	41	30	14.5	6	-	26	33	4.5	FEB 1210 A

Basic Load Rating		Nut Rigidity N/μm
N		
Dynamic Ca	Static Coa	164 / 138
1000 / 640	3300 / 1650	
		Preload type
		Backlash type

- Note 1) The diameter of one of the Screw Shaft ends must be less than the Screw Shaft Root diameter, otherwise Ball Nut cannot be installed.
- Note 2) Ball Nut dimension is without seal at the both ends. If the seals are required, Ball Nut dimension should be changed, in that case, please ask KSS. Some type of Ball Nuts cannot equip with seals, please ask KSS representative.
- Note 3) The Rigidity values shown in the table are theoretical values of Ball Nut Rigidity calculated from the amount of Elastic Displacement under the following conditions. Backlash type ; Apply the Axial load equivalent to 30% of the Basic Dynamic Load Rating Ca. Preload type ; Apply the Preload equivalent to 5% of the Basic Dynamic Load Rating Ca. For Axial load or Preload condition other than the above, see the formula in p-A823, you can calculate Rigidity using this formula.
- Note 4) All models are Right-hand Screw. If Left-hand Screw is required, please ask KSS representative.
- Note 5) Basic Load Rating and Rigidity for Backlash type and Preload type are described in the same cell.



Precision Ball Screws

Single Nut with Flange

Backlash type/Preload type

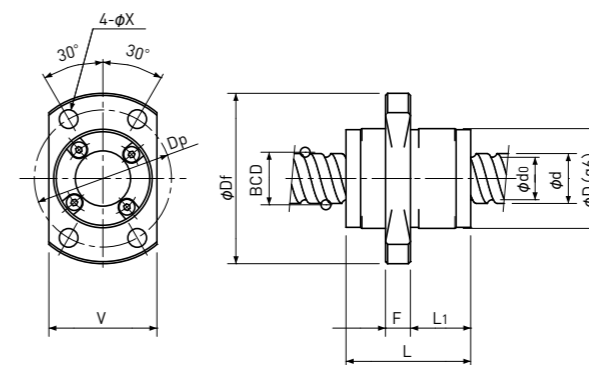

Type-3:End-cap type or End-deflector type

Unit: mm

Ball Nut Model number	Shaft nominal dia. d	Lead	Ball size	BCD	Lead angle	Root dia. d ₀	Number of Circuit	Basic Load Rating		Nut Rigidity N/μm	Nut dimension									Ball Nut Model number	
								N			Nut type	D	Df	L	L ₁	F	W	V	Dp		Bolt Hole X
								Dynamic Ca	Static Coa												
FEB 1312 A	13	12	2.381	13.50	15° 48'	11.0	1.6×2	5000 / -	9900 / -	151 / -	3	28	45	30	17	5	-	30	37	4.5	FEB 1312 A
FEB 1315 A	13	15	2.381	13.50	19° 29'	11.0	1.6×2	5000 / -	10300 / -	147 / -	3	28	45	35	22	5	-	30	37	4.5	FEB 1315 A
FEB 1320 A	13	20	2.381	13.50	25° 15'	11.0	1.6×2	5000 / -	10700 / -	142 / -	3	28	45	43	29	5	-	30	37	4.5	FEB 1320 A

Basic Load Rating		Nut Rigidity N/μm
N		
Dynamic Ca	Static Coa	164 / 138
1000 / 640	3300 / 1650	

Preload type
Backlash type

- Note 1) The diameter of one of the Screw Shaft ends must be less than the Screw Shaft Root diameter, otherwise Ball Nut cannot be installed.
- Note 2) Ball Nut dimension is without seal at the both ends. If the seals are required, Ball Nut dimension should be changed, in that case, please ask KSS. Some type of Ball Nuts cannot equip with seals, please ask KSS representative.
- Note 3) The Rigidity values shown in the table are theoretical values of Ball Nut Rigidity calculated from the amount of Elastic Displacement under the following conditions.
Backlash type ; Apply the Axial load equivalent to 30% of the Basic Dynamic Load Rating Ca.
Preload type ; Apply the Preload equivalent to 5% of the Basic Dynamic Load Rating Ca.
For Axial load or Preload condition other than the above, see the formula in p-A823, you can calculate Rigidity using this formula.
- Note 4) All models are Right-hand Screw. If Left-hand Screw is required, please ask KSS representative.
- Note 5) Basic Load Rating and Rigidity for Backlash type and Preload type are described in the same cell.



Precision Ball Screws

Single Nut with Flange

Backlash type/Preload type

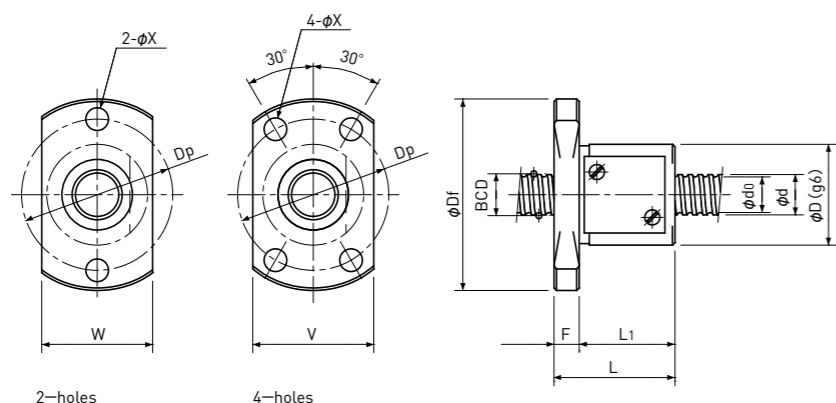

Type-1:Return-plate type

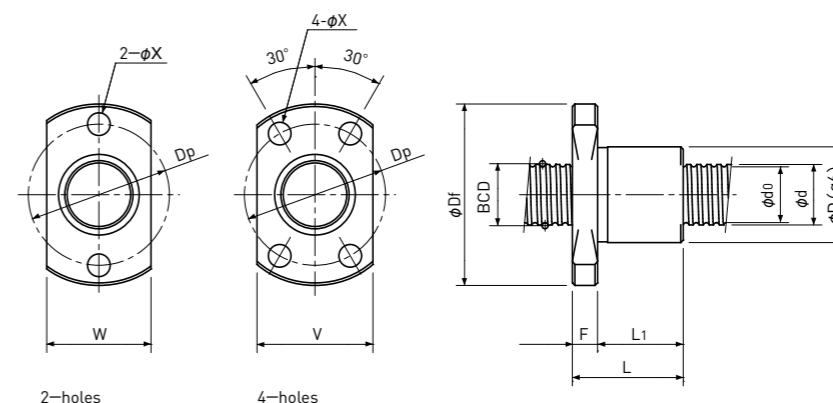

Type-2:Internal-deflector type or End-deflector type

Unit: mm

Ball Nut Model number	Shaft nominal dia. d	Lead	Ball size	BCD	Lead angle	Root dia. d ₀	Number of Circuit	Basic Load Rating		Nut Rigidity N/μm	Nut dimension									Ball Nut Model number	
								N			Nut type	D	Df	L	L ₁	F	W	V	Dp		Bolt Hole X
								Dynamic Ca	Static Coa												
FBS 1401 B	14	1	0.8	14.15	1°17'	13.3	3.7×1	960 / 610	2900 / 1450	148 / 124	1	26	46	21	15	6	28	28	37	5.5	FBS 1401 B
FKB 1402 A	14	2	1.2	14.30	2°33'	13.0	1×3	1700 / 1700	4300 / 4300	122 / 190	2	21	40	20	14	6	23	26	31	5.5	FKB 1402 A
FBS 1402 B	14	2	1.5875	14.30	2°33'	12.6	3.7×1	3200 / 2000	7500 / 3800	176 / 148	1	26	46	25	19	6	28	28	37	5.5	FBS 1402 B
FKB 1402.5 A	14	2.5	1.5875	14.40	3°10'	12.7	1×3	2500 / 2500	5600 / 5600	127 / 197	2	22	41	22	16	6	24	26	32	5.5	FKB 1402.5 A
FBS 1402.5 B	14	2.5	1.5875	14.30	3°11'	12.6	3.7×1	3200 / 2000	7500 / 3700	176 / 148	1	28	48	27	21	6	30	30	39	5.5	FBS 1402.5 B
FKB 1403 A	14	3	2.0	14.50	3°46'	12.4	1×3	3400 / 3400	6800 / 6800	131 / 204	2	24	43	32	26	6	26	27	34	5.5	FKB 1403 A
FBS 1403 B	14	3	2.0	14.30	3°49'	12.2	3.7×1	4600 / 2900	10100 / 5000	184 / 154	1	30	51	30	24	6	32	32	42	5.5	FBS 1403 B
FKB 1404 A	14	4	2.381	14.65	4°58'	11.9	1×3	4500 / 4500	8600 / 8600	136 / 212	2	26	45	29	23	6	28	28	36	5.5	FKB 1404 A
FBS 1404 B	14	4	2.381	14.30	5°05'	11.8	3.7×1	5700 / 3600	11600 / 5800	187 / 157	1	30	51	33	27	6	32	32	42	5.5	FBS 1404 B
FBS 1405 B	14	5	2.381	14.30	6°21'	11.8	3.7×1	5700 / 3600	11600 / 5800	186 / 157	1	30	51	39	33	6	32	32	42	5.5	FBS 1405 B

Basic Load Rating		Nut Rigidity N/μm
Dynamic Ca	Static Coa	
1000 / 640	3300 / 1650	164 / 138
		Preload type
		Backlash type

- Note 1) The diameter of one of the Screw Shaft ends must be less than the Screw Shaft Root diameter, otherwise Ball Nut cannot be installed.
- Note 2) Ball Nut dimension is without seal at the both ends. If the seals are required, Ball Nut dimension should be changed, in that case, please ask KSS. Some type of Ball Nuts cannot equip with seals, please ask KSS representative.
- Note 3) The Rigidity values shown in the table are theoretical values of Ball Nut Rigidity calculated from the amount of Elastic Displacement under the following conditions.
Backlash type ; Apply the Axial load equivalent to 30% of the Basic Dynamic Load Rating Ca.
Preload type ; Apply the Preload equivalent to 5% of the Basic Dynamic Load Rating Ca.
For Axial load or Preload condition other than the above, see the formula in p-A823, you can calculate Rigidity using this formula.
- Note 4) All models are Right-hand Screw. If Left-hand Screw is required, please ask KSS representative.
- Note 5) Basic Load Rating and Rigidity for Backlash type and Preload type are described in the same cell.



Precision Ball Screws

Single Nut with Flange

Backlash type/Preload type

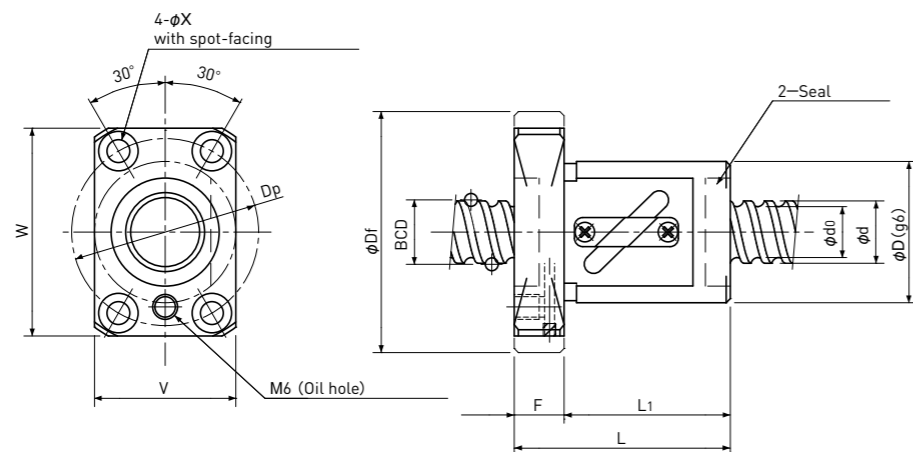

Type-4:Return-tube type

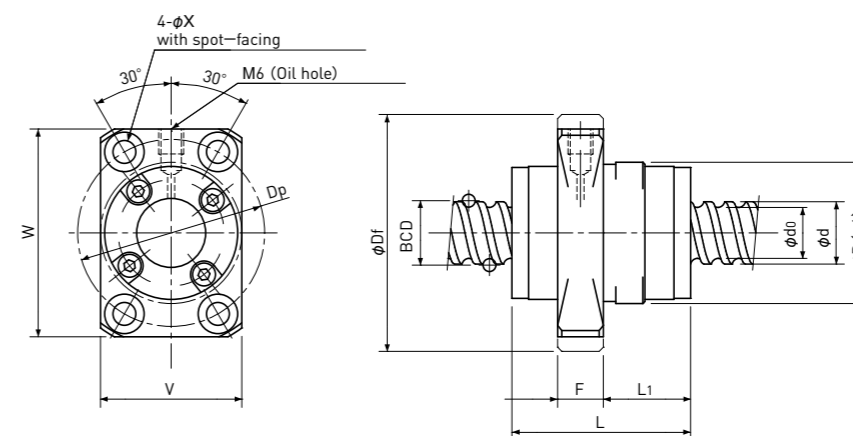

Type-5:End-deflector type

Unit: mm

Ball Nut Model number	Shaft nominal dia. d	Lead	Ball size	BCD	Lead angle	Root dia. d ₀	Number of Circuit	Basic Load Rating		Nut Rigidity N/μm	Nut dimension										Ball Nut Model number
								N			D	Df	L	L ₁	F	W	V	Dp	Bolt Hole X		
								Dynamic C _a	Static C _{0a}												
FBS 1504 T	15	4	2.381	15.50	4° 42'	13.0	2.5×1	4100 / 2580	8550 / 4300	136 / 112	4	32	56	41	31	10	48	32	43	5.5	FBS 1504 T
FEB 1505 A(1)	15	5	3.175	15.50	5° 41'	12.2	3.7×1	8900 / -	17000 / -	208 / -	5	32	55	33	16	11	49	33	43	5.5	FEB 1505 A(1)
FEB 1505 A(2)	15	5	3.175	15.50	5° 41'	12.2	3.7×1	8900 / -	17000 / -	208 / -	5	34	57	33	16	11	50	34	45	5.5	FEB 1505 A(2)
FBS 1505 T	15	5	3.175	15.80	5° 45'	12.4	2.5×1	6900 / 4350	12500 / 6250	148 / 122	4	34	58	44	34	10	50	34	45	5.5	FBS 1505 T
FEB 1510 A(1)	15	10	3.175	15.50	11° 36'	12.2	2.7×2	12000 / -	25000 / -	289 / -	5	32	55	43	21	11	49	33	43	5.5	FEB 1510 A(1)
FEB 1510 A(2)	15	10	3.175	15.50	11° 36'	12.2	2.7×2	12000 / -	25000 / -	289 / -	5	34	57	43	21	11	50	34	45	5.5	FEB 1510 A(2)
FBS 1510 T	15	10	3.175	15.80	11° 23'	12.4	1.5×1	4400 / 2540	7900 / 3450	87 / 69	4	34	58	52	40	12	50	34	45	6.0	FBS 1510 T
FEB 1520 A(1)	15	20	3.175	15.75	22° 1'	12.4	1.7×2	8000 / -	16000 / -	178 / -	5	32	55	52	28.5	11	49	33	43	5.5	FEB 1520 A(1)
FEB 1520 A(2)	15	20	3.175	15.75	22° 1'	12.4	1.7×2	8000 / -	16000 / -	178 / -	5	34	57	52	28.5	11	50	34	45	5.5	FEB 1520 A(2)
FBS 1520 T	15	20	3.175	15.80	21° 56'	12.4	1.5×1	4400 / 2540	7900 / 3450	84 / 67	4	34	58	62	50	12	50	34	45	6.0	FBS 1520 T
FEB 1530 A(1)	15	30	3.175	15.75	31° 14'	12.4	1.7×2	8000 / -	16000 / -	163 / -	5	32	55	71	45.5	11	49	33	43	5.5	FEB 1530 A(1)
FEB 1530 A(2)	15	30	3.175	15.75	31° 14'	12.4	1.7×2	8000 / -	16000 / -	163 / -	5	34	57	71	45.5	11	50	34	45	5.5	FEB 1530 A(2)

Basic Load Rating		Nut Rigidity N/μm
Dynamic C _a	Static C _{0a}	
1000 / 640	3300 / 1650	164 / 138
		Preload type
		Backlash type

- Note 1) The diameter of one of the Screw Shaft ends must be less than the Screw Shaft Root diameter, otherwise Ball Nut cannot be installed.
- Note 2) Ball Nut dimension is without seal at the both ends.
If the seals are required, Ball Nut dimension should be changed, in that case, please ask KSS.
Some type of Ball Nuts cannot equip with seals, please ask KSS representative.
- Note 3) The Rigidity values shown in the table are theoretical values of Ball Nut Rigidity calculated from the amount of Elastic Displacement under the following conditions.
Backlash type ; Apply the Axial load equivalent to 30% of the Basic Dynamic Load Rating C_a.
Preload type ; Apply the Preload equivalent to 5% of the Basic Dynamic Load Rating C_a.
For Axial load or Preload condition other than the above, see the formula in p-A823, you can calculate Rigidity using this formula.
- Note 4) All models are Right-hand Screw. If Left-hand Screw is required, please ask KSS representative.
- Note 5) Basic Load Rating and Rigidity for Backlash type and Preload type are described in the same cell.



Precision Ball Screws

Single Nut with Flange

Backlash type/Preload type

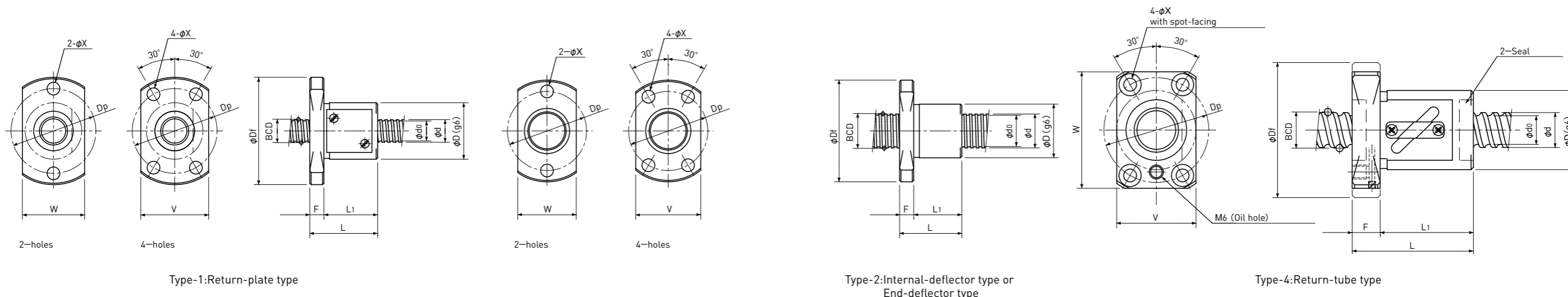

Unit: mm

Ball Nut Model number	Shaft nominal dia. d	Lead	Ball size	BCD	Lead angle	Root dia. d ₀	Number of Circuit	Basic Load Rating		Nut Rigidity N/μm	Nut dimension										Ball Nut Model number
								N			D	Df	L	L ₁	F	W	V	Dp	Bolt Hole X		
								Dynamic Ca	Static Coa												
FBS 1601 B	16	1	0.8	16.15	1°08'	15.3	3.7×1	1000 / 640	3300 / 1650	164 / 138	1	28	48	21	15	6	30	30	39	5.5	FBS 1601 B
FKB 1602 A	16	2	1.2	16.30	2°15'	15.0	1×3	1850 / 1850	5000 / 5000	137 / 213	2	24	43	20	14	6	26	27	34	5.5	FKB 1602 A
FBS 1602 B	16	2	1.5875	16.30	2°14'	14.6	3.7×1	3400 / 2100	8600 / 4300	197 / 163	1	28	48	25	19	6	30	30	39	5.5	FBS 1602 B
FKB 1602.5 A	16	2.5	1.5875	16.40	2°47'	14.7	1×3	2700 / 2700	6500 / 6500	142 / 221	2	24	43	22	16	6	26	27	34	5.5	FKB 1602.5 A
FBS 1602.5 B	16	2.5	1.5875	16.30	2°48'	14.6	3.7×1	3400 / 2100	8600 / 4300	197 / 163	1	28	48	27	21	6	30	30	39	5.5	FBS 1602.5 B
FKB 1603 A	16	3	2.0	16.50	3°19'	14.4	1×3	3600 / 3600	8000 / 8000	146 / 227	2	26	45	32	26	6	28	28	36	5.5	FKB 1603 A
FBS 1603 B	16	3	2.0	16.30	3°21'	14.2	3.7×1	4900 / 3100	11600 / 5800	205 / 172	1	32	53	30	24	6	34	34	44	5.5	FBS 1603 B
FKB 1604 A	16	4	2.381	16.65	4°22'	13.9	1×3	4800 / 4800	10000 / 10000	152 / 237	2	28	47	29	23	6	30	30	38	5.5	FKB 1604 A
FBS 1604 B	16	4	2.381	16.30	4°28'	13.8	3.7×1	6200 / 3900	13600 / 6800	209 / 174	1	34	54	34	28	6	36	36	45	5.5	FBS 1604 B
FBS 1605 B	16	5	3.175	16.50	5°31'	13.2	3.7×1	9100 / 5700	18200 / 9100	217 / 182	1	38	57	42	36	6	40	40	48	5.5	FBS 1605 B
FBS 2005 T	20	5	3.175	20.80	4°23'	17.5	2.5×1	8350 / 5260	17500 / 8750	189 / 157	4	40	68	48	36	12	60	40	53	6.6	FBS 2005 T
FBS 2010 T	20	10	4.7625	21.00	8°37'	17.7	2.5×1	13500 / 8350	25100 / 12800	195 / 160	4	46	74	65	50	15	66	46	59	6.6	FBS 2010 T

Basic Load Rating		Nut Rigidity N/μm
Dynamic Ca	Static Coa	
1000 / 640	3300 / 1650	164 / 138
		Preload type
		Backlash type

- Note 1) The diameter of one of the Screw Shaft ends must be less than the Screw Shaft Root diameter, otherwise Ball Nut cannot be installed.
- Note 2) Ball Nut dimension is without seal at the both ends.
If the seals are required, Ball Nut dimension should be changed, in that case, please ask KSS.
Some type of Ball Nuts cannot equip with seals, please ask KSS representative.
- Note 3) The Rigidity values shown in the table are theoretical values of Ball Nut Rigidity calculated from the amount of Elastic Displacement under the following conditions.
Backlash type ; Apply the Axial load equivalent to 30% of the Basic Dynamic Load Rating Ca.
Preload type ; Apply the Preload equivalent to 5% of the Basic Dynamic Load Rating Ca.
For Axial load or Preload condition other than the above, see the formula in p-A823, you can calculate Rigidity using this formula.
- Note 4) All models are Right-hand Screw. If Left-hand Screw is required, please ask KSS representative.
- Note 5) Basic Load Rating and Rigidity for Backlash type and Preload type are described in the same cell.