



Single nut with flange mount



Rolled Ball Screws

Single Nut with Flange

Backlash type

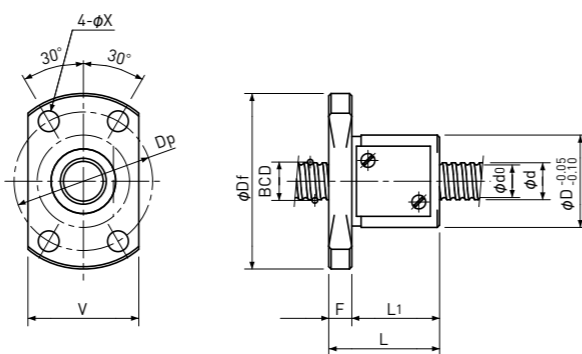

Type-1:Return-plate type

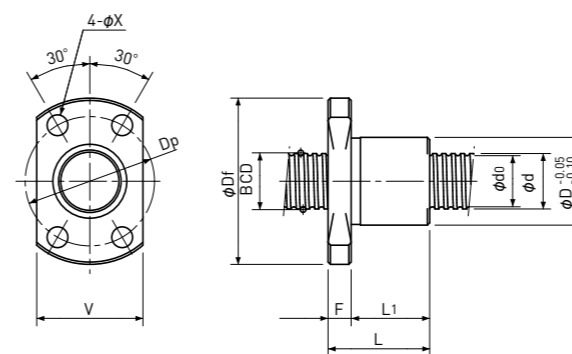

Type-2:End-deflector type

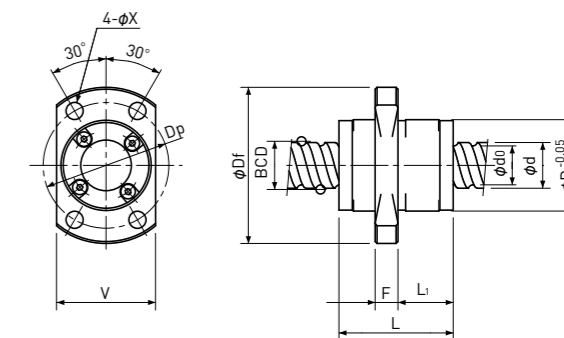

Type-3:End-cap type or End-deflector type

Unit: mm

Ball Nut Model number	Shaft nominal dia. d	Lead	Ball size	BCD	Lead angle	Root dia. d ₀	Number of Circuit	Basic Load Rating		Nut Rigidity N/μm	Nut dimension										Ball Nut Model number
								N			Nut type	D	Df	L	L ₁	F	W	V	Dp	Bolt Hole X	
								Dynamic Ca	Static Coa												
MRB 0401	4	1	0.8	4.15	4° 23'	3.3	3.7×1	560	790	54	1	11	23	17	13	4	—	15	17	3.4	MRB 0401
MRB 0402	4	2	0.8	4.15	8° 43'	3.3	2.7×1	420	570	39	1	11	23	19	15	4	—	15	17	3.4	MRB 0402
MRB 0504	5	4	0.8	5.15	13° 53'	4.3	2.7×1	470	720	47	1	12	24	22	18	4	—	16	18	3.4	MRB 0504
MRB 0601 **	6	1	0.8	6.15	2° 58'	5.3	3.7×1	680	1200	75	1	13	26	17	13	4	—	16	20	3.4	MRB 0601 **
MRB 0602	6	2	1.0	6.20	5° 52'	5.1	2.7×1	750	1200	58	1	15	28	17	13	4	—	19	22	3.4	MRB 0602
MRB 0606	6	6	1.0	6.30	16° 52'	5.2	1.6×2	870	1450	67	3	14	27	17	8	4	—	16	21	3.4	MRB 0606
MRB 0610	6	10	1.2	6.30	26° 48'	5.0	1.2×2	950	1600	50	3	14	27	23	11.5	4	—	16	21	3.4	MRB 0610
MRB 0801 **	8	1	0.8	8.15	2° 15'	7.3	3.7×1	780	1650	95	1	16	29	17	13	4	—	18	23	3.4	MRB 0801 **
MRB 0802 **	8	2	1.5875	8.30	4° 23'	6.6	3.7×1	2400	4100	111	1	20	37	24	19	5	—	22	29	4.5	MRB 0802 **
MRB 0802.5	8	2.5	1.5875	8.00	5° 41'	6.3	2.7×1	1850	3000	80	2	16	29	16	12	4	—	18	23	3.4	MRB 0802.5
MRB 0805	8	5	1.5875	8.30	10° 51'	6.6	2.7×1	1850	3000	82	1	18	31	28	24	4	—	20	25	3.4	MRB 0805
MRB 0808	8	8	1.5875	8.40	16° 52'	6.7	1.6×2	2200	3800	95	3	18	31	20	10	4	—	20	25	3.4	MRB 0808
MRB 0810	8	10	1.5875	8.40	20° 45'	6.7	1.6×2	2200	3800	92	3	18	31	24	13	4	—	20	25	3.4	MRB 0810
MRB 0812	8	12	1.5875	8.40	24° 27'	6.7	1.6×2	2200	4000	90	3	18	31	27	17	4	—	20	25	3.4	MRB 0812

Note 1) All models are Right-hand screw.

Note 2) The diameter of the Screw Shaft both ends must be less than the Screw Shaft Root diameter, because of production and Nut assembly reason. If bigger end-journal than Shaft diameter is required, please consult KSS.

Note 3) Ball Nut dimension is without seal at the both ends. All type of Ball Nuts cannot equip with seals.

Note 4) Rigidity

The Rigidity values shown in the table are theoretical values calculated from the amount of Elastic Displacement under the Axial load equivalent to 30% of the Basic Dynamic Load Rating Ca.

For Axial load condition other than the above, see the formula in p-A823, you can calculate Rigidity using this formula.

Note 5) Stainless Rolled Ball Screw

Stainless Rolled Ball Screw is available for Ball Nut Model Number marked **.



Rolled Ball Screws

Single Nut with Flange

Backlash type

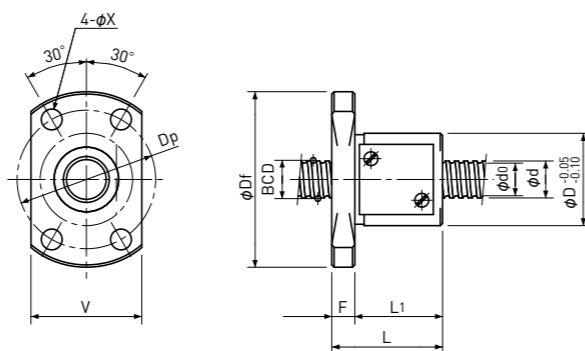

Type-1:Return-plate type

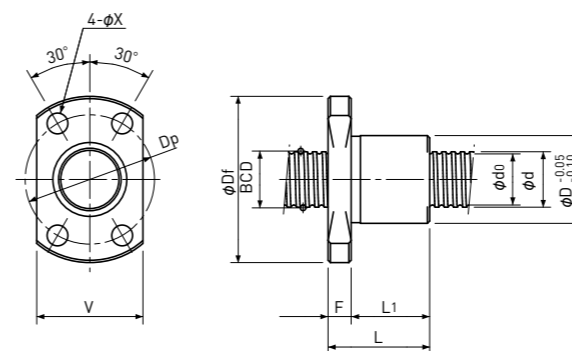

Type-2:End-deflector type

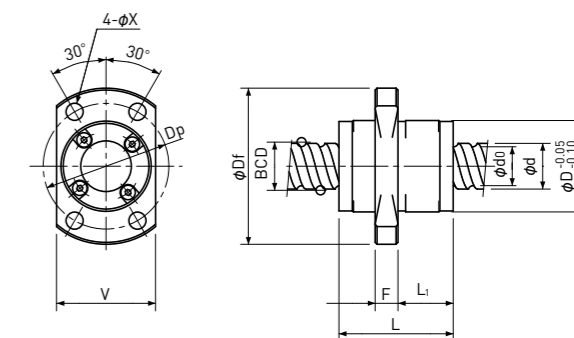

Type-3:End-cap type or End-deflector type

Unit: mm

Ball Nut Model number	Shaft nominal dia. d	Lead	Ball size	BCD	Lead angle	Root dia. do	Number of Circuit	Basic Load Rating		Nut Rigidity N/μm	Nut dimension										Ball Nut Model number
								N			Nut type	D	Df	L	L1	F	W	V	Dp	Bolt Hole X	
								Dynamic Ca	Static Coa												
MRB 1002 **	10	2	1.5875	10.30	3°32'	8.6	3.7×1	2700	5300	134	1	23	40	24	19	5	—	25	32	4.5	MRB 1002 **
MRB 1004	10	4	2.0	10.30	7°03'	8.2	2.7×1	3000	5200	104	1	24	41	28	23	5	—	26	33	4.5	MRB 1004
MRB 1005	10	5	2.0	10.30	8°47'	8.2	2.7×1	3000	5200	103	2	23	40	26	21	5	—	25	32	4.5	MRB 1005
MRB 1006	10	6	2.0	10.30	10°30'	8.2	2.7×1	3000	5000	102	1	26	42	33	28	5	—	28	34	4.5	MRB 1006
MRB 1010	10	10	2.0	10.50	16°52'	8.4	1.6×2	3300	5900	117	3	23	40	24	13	5	—	25	32	4.5	MRB 1010
MRB 1012	10	12	2.0	10.50	19°59'	8.4	1.6×2	3300	6200	115	3	23	40	28	17	5	—	25	32	4.5	MRB 1012
MRB 1015	10	15	2.0	10.50	24°27'	8.4	1.6×2	3300	6400	110	3	23	40	33	22	5	—	25	32	4.5	MRB 1015
MRB 1020	10	20	1.5875	10.40	31°28'	8.7	0.7×4	2100	4000	88	3	20	37	23	13	5	—	22	29	4.5	MRB 1020

Note 1) All models are Right-hand screw.

Note 2) The diameter of the Screw Shaft both ends must be less than the Screw Shaft Root diameter, because of production and Nut assembly reason. If bigger end-journal than Shaft diameter is required, please consult KSS.

Note 3) Ball Nut dimension is without seal at the both ends. All type of Ball Nuts cannot equip with seals.

Note 4) Rigidity

The Rigidity values shown in the table are theoretical values calculated from the amount of Elastic Displacement under the Axial load equivalent to 30% of the Basic Dynamic Load Rating Ca.

For Axial load condition other than the above, see the formula in p-A823, you can calculate Rigidity using this formula.

Note 5) Stainless Rolled Ball Screw

Stainless Rolled Ball Screw is available for Ball Nut Model Number marked **.



Rolled Ball Screws

Single Nut with Flange

Backlash type

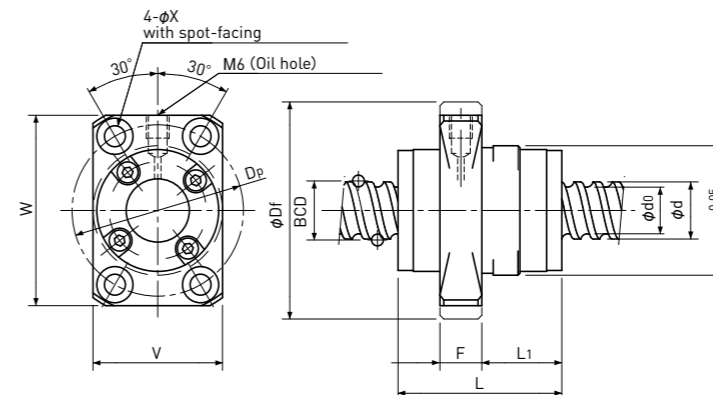
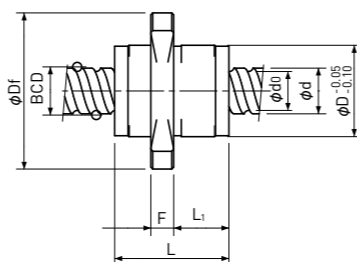
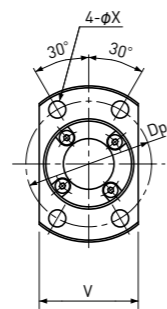
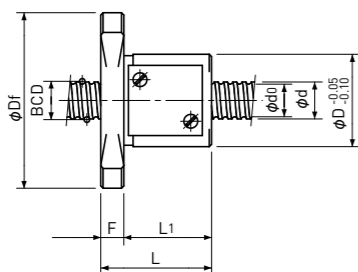
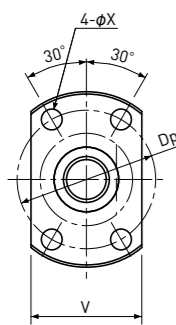

Type-1:Return-plate type

Type-3:End-cap type or End-deflector type

Type-4:End-deflector type

Unit: mm

Ball Nut Model number	Shaft nominal dia. d	Lead	Ball size	BCD	Lead angle	Root dia. d ₀	Number of Circuit	Basic Load Rating		Nut Rigidity N/μm	Nut dimension										Ball Nut Model number
								N			Nut type	D	Df	L	L ₁	F	W	V	Dp	Bolt Hole X	
								Dynamic Ca	Static Coa												
MRB 1202	12	2	1.5875	12.30	2° 58'	10.6	3.7×1	3000	6400	156	1	25	42	24	19	5	—	27	34	4.5	MRB 1202
MRB 1210	12	10	2.381	12.65	14° 07'	10.2	1.7×2	5100	9800	152	3	24	41	30	14.5	6	—	26	33	4.5	MRB 1210
MRB 1312	13	12	2.381	13.50	15° 48'	11.0	1.6×2	5000	9900	151	3	28	45	30	17	5	—	30	37	4.5	MRB 1312
MRB 1315	13	15	2.381	13.50	19° 29'	11.0	1.6×2	5000	10300	147	3	28	45	35	22	5	—	30	37	4.5	MRB 1315
MRB 1320	13	20	2.381	13.50	25° 15'	11.0	1.6×2	5000	10700	142	3	28	45	43	29	5	—	30	37	4.5	MRB 1320
MRB 1402	14	2	1.5875	14.30	2° 33'	12.6	3.7×1	3200	7500	176	1	26	45	25	19	6	—	28	36	5.5	MRB 1402
MRB 1404	14	4	2.381	14.30	5° 05'	11.8	3.7×1	5700	11600	187	1	30	49	33	27	6	—	32	40	5.5	MRB 1404
MRB 1505(1)	15	5	3.175	15.50	5° 41'	12.2	3.7×1	8900	17000	208	4	32	55	33	16	11	49	33	43	5.5	MRB 1505(1)
MRB 1505(2)	15	5	3.175	15.50	5° 41'	12.2	3.7×1	8900	17000	208	4	34	57	33	16	11	50	34	45	5.5	MRB 1505(2)
MRB 1510(1)	15	10	3.175	15.50	11° 36'	12.2	2.7×2	12000	25000	289	4	32	55	43	21	11	49	33	43	5.5	MRB 1510(1)
MRB 1510(2)	15	10	3.175	15.50	11° 36'	12.2	2.7×2	12000	25000	289	4	34	57	43	21	11	50	34	45	5.5	MRB 1510(2)
MRB 1520(1)	15	20	3.175	15.75	22° 01'	12.7	1.7×2	8000	16000	178	4	32	55	52	28.5	11	49	33	43	5.5	MRB 1520(1)
MRB 1520(2)	15	20	3.175	15.75	22° 01'	12.7	1.7×2	8000	16000	178	4	34	57	52	28.5	11	50	34	45	5.5	MRB 1520(2)

Note 1) All models are Right-hand screw.

Note 2) The diameter of the Screw Shaft both ends must be less than the Screw Shaft Root diameter, because of production and Nut assembly reason. If bigger end-journal than Shaft diameter is required, please consult KSS.

Note 3) Ball Nut dimension is without seal at the both ends. All type of Ball Nuts cannot equip with seals.

Note 4) Rigidity

The Rigidity values shown in the table are theoretical values calculated from the amount of Elastic Displacement under the Axial load equivalent to 30% of the Basic Dynamic Load Rating Ca.

For Axial load condition other than the above, see the formula in p-A823, you can calculate Rigidity using this formula.

Note 5) Stainless Rolled Ball Screw

Stainless Rolled Ball Screw is available for Ball Nut Model Number marked **.